

Commercial Air Conditioners 2021/2022



**Fan Coil Unit &
Air-Cooled Chiller &
Water-Cooled Scroll Chiller**

Established in 1991

TICA is a professional enterprise specialized in R&D, manufacturing, sales and services of environment cleaning and thermal energy utilization.

Vision

Strive to be the international leading integrated system and service provider in clean environment and utilization of thermal energy

Mission

Persist to maximize the value for customers through innovative technology and provide clean environment in order to improve the quality of life

TICA is a national high-tech enterprise, a single leading enterprise cultivated by the Ministry of Industry and Information Technology, a national brand cultivation enterprise of the Ministry of Industry and Information Technology, and a vice chairman member of China Refrigeration and Air-conditioning Industry Association. It has a national-recognized enterprise technology center, an enterprise academician workstation, and a post-doctoral research workstation. Its projects cover Beijing Bird's Nest Stadium, Water Cube, Wukesong Indoor Stadium, PetroChina, Sinopec, State Grid, Nanjing Panda, Hangzhou Xiaoshan International Airport, Hainan Airlines Group, Shangri-La Hotel, Manila Ocean Park, Abu Dhabi Al Muneera, SM City in Philippines and Unilever, etc.

TICA is also the outstanding provider of central air conditioners for China's subway networks and has successfully served nearly 70 key subway lines in major cities such as Beijing, Shanghai, Guangzhou, Shenzhen, Chengdu, Suzhou, Hangzhou and Tianjin. TICA is a professional supplier and service provider in China that specializes in system integration of clean environment. While for microelectronics, hospital operating rooms, biopharmaceutical industry and other professional purification areas, each achieving a market share of over 40%.

TICA, Visible Cleanness
TICA, Visible Energy-Saving



Contents

Air-Cooled Chiller	P01
Air-Cooled Rotor Chiller	
Air To Water Split Heat Pump Chiller	P01
Air-Cooled Scroll Chiller	
Modular Inverter Air-cooled Scroll Chiller	P16
Modular Fixed Frequency Air-cooled Scroll Chiller	P30
Large Air-cooled Scroll Chiller	P48
Water-Cooled Scroll Chiller	P56
Fan Coil Unit	P69
Standard Duct	P69
Silent Duct	P76
High Static Pressure Duct	P80
Round Flow Cassette	P83
Ceiling & Floor	P86

Air To Water Split Heat Pump Chiller



Nomenclature

Full Inverter Split heat pump

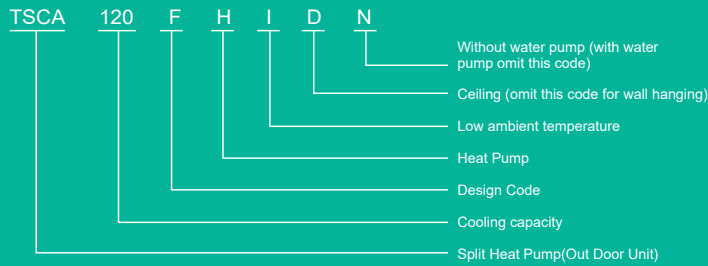
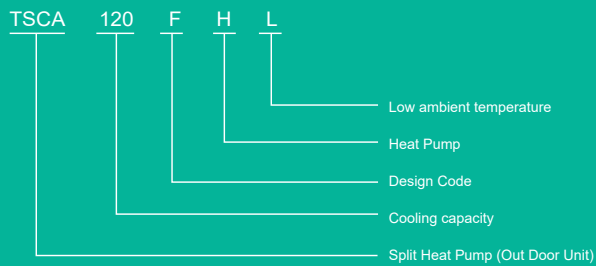

Health

Radiation Heating for Healthier Life

Comfortable Temperature Field

Heating with Traditional Air Conditioner

The temperature gradually decreases from top down. When the ceiling temperature reaches 30°C, the floor temperature is only about 10°C.

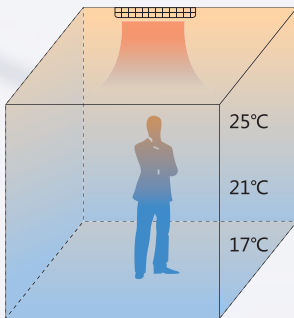

Temperature pattern of air conditioning system

Warm for head and cool for feet

Uncomfortable
Increasing the risks of rheumatism and arthritis

Split heat pump Heating

The temperature gradually decreases from bottom up. The temperature field is distributed evenly because of even heat dissipation and large heat dissipation area of the whole floor .

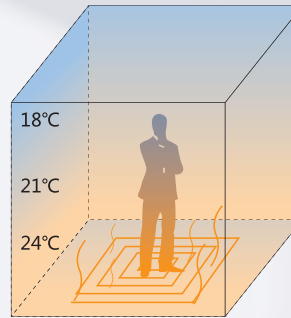

Temperature pattern of floor heating

Cool for head and warm for feet

Complying with human thermal engineering rules
Improving blood circulation and metabolism of the body

Perfect Humidity Range to Make Your Home More Comfortable

Traditional Fluoride-System Air Conditioner	Split heat pump Air Conditioning System
<p>When cooling, the refrigerant directly evaporates indoors at a low temperature, the air outlet temperature is very low and uncomfortable.</p> <p>Condensate water is generated when the low temperature surface of coil unit is exposed to the hot air. As a result, the indoor air is excessively dehumidified (indoor humidity of about 35%).</p>	<p>When cooling, the water temperature can be set and is generally over 7°C, which not only guarantees the cooling effect, but also dehumidifies the air properly, keeping the indoor humidity within the most comfortable range (about 50%). In addition, the air outlet temperature is more approximate to the human body temperature, letting you feel cool but not cold.</p>

Fast Cooling/Heating and Constant Room Temperature to Make You More Pleasant

After the air conditioner is powered on, the compressor rapidly starts and the unit operates at a high frequency to reach the set indoor temperature promptly. In addition, the system regulates the output of ODU and indoor water supply flow/temperature in real time based on the change of indoor load, to control the room temperature accurately. With Split heat pump full inverter air source chiller (heat pump), the room temperature fluctuates $\pm 1^{\circ}\text{C}$, resolving the "unstable temperature" issue of traditional air conditioners and making you feel more comfortable.

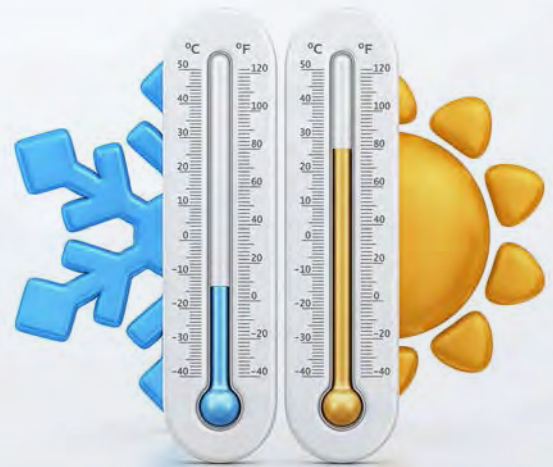
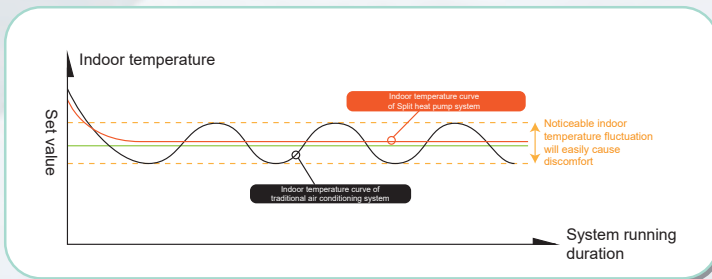

Wide Adaptability for Cooling and Heating

Model	Operating range:
Cooling	-15°C to 55°C
Heating	-25°C to 25°C



Quiet Enjoyment and Better Household Experience

The unit uses 9-tier noise reduction technologies to effectively reduce the noise when the unit is started, runs in full load, and runs in partial load. Three silent modes provide more all-day noise reduction solutions for household life.



Smart day
silent mode

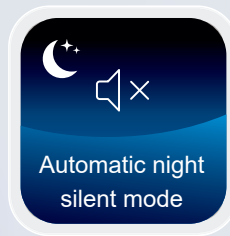

Automatic night
silent mode



Powerful night
silent mode



Peaceful suburb



IDU running



Library



Quiet off

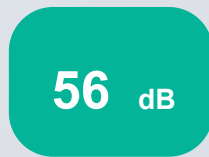

ODU running



Chatting in
living room

TIPS

When floor heating is used in a radiation manner, because no moving parts such as fans and motors are installed indoors, nearly no noise is generated and family members can enjoy a peaceful space.



Energy Saving



Upgrade 1
(Mitsubishi)

All DC inverter compliant enhanced vapor injection compressor
Match the running frequency smartly based on the load change in the air side.



Upgrade 2

(Grundfos of Denmark)

High-efficiency inverter screening water pu
Regulate the system water flow smartly based on the load change in the air side.

Ons-stop configuration upgrad



Upgrade 3

(Shibaura of Japan)

High-efficiency anti-interference inverter mot
Match the air flow smartly based on the load change in the air side.

Multi-inverter for Performance Assurance

Air to water split heat pump chiller upgrades product configurat on to the top-level industry standard at one stop. With the all DC inverter compliant enhanced vapor injection compressor as its core of energy saving, it also adopts the high-efficiency anti-interference inverter motor and inverter screening water pump, to regulate running status in real time, improve energy efficiency effectiv .

Three-in-one for Powerful Force

All DC inverter + Rotor compressor + enhanced vapor injection

The cooling capability is not attenuated at 40°C, and the heating capability is not attenuated at -20°C.



All DC inverter vs. fixed-speed compressor
Automatically regulate the unit frequency to meet the indoor capability requirements to the maximum extent while guaranteeing energy saving.

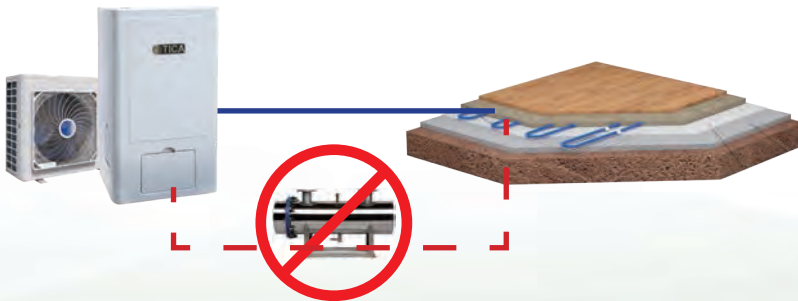
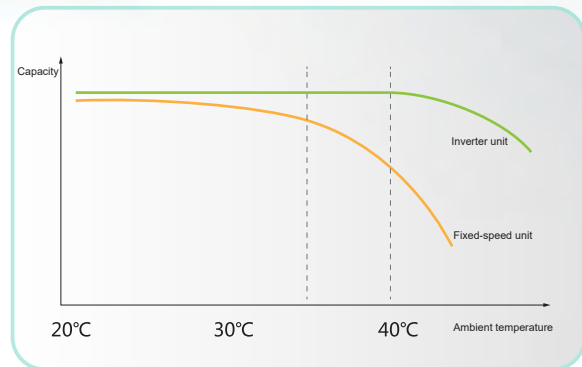

Electric heater is not required

Enhanced vapor injection vs. common system
TICA's original all-condition enhanced vapor injection technology is used in Air to water split heat pump chiller, fully improving the unit running capability of cooling and heating. It easily implements cooling and heating in extreme conditions, with energy efficiency 20% higher than common units.

No electric auxiliary heat is needed in low-temperature environments in winter, saving more energy.

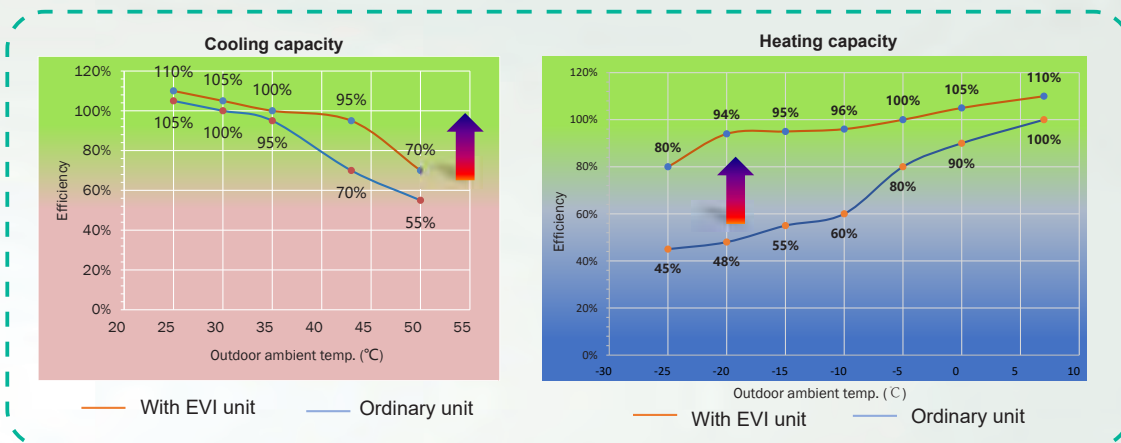

Superpower Heat Storage for Long-term Heat Preservation

Air To Water Split Heat Pump Chiller taking water as the cool/heat carrier, provides a large heat capacity and powerful heat storage capabilities, beneficial for long-term heat preservation indoors. One hour later after the unit is powered off, the indoor environment temperature decreases by 2°C only.

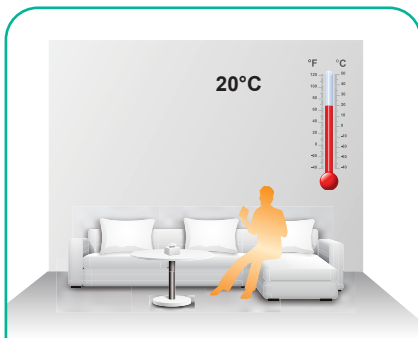

20°C

Room with normal heating

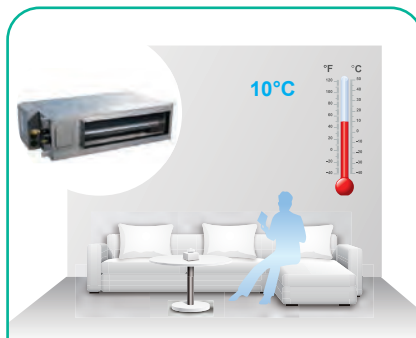

10°C

One hour later after the unit is powered off
Room heated by traditional air conditioner

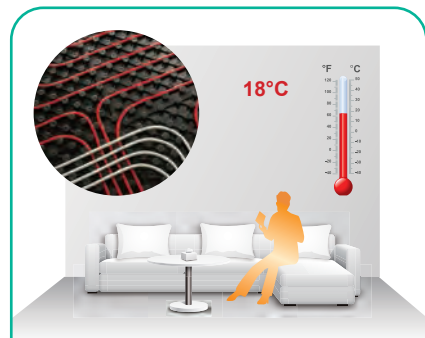

18°C

One hour later after the unit is powered off
Room heated by Split heat pump

Excellent Energy Efficiency

Air To Water Split Heat Pump Chiller provides an excellent energy efficiency level, with the integrated part load value (IPLV) reaching 4.3, far exceeding the national level-1 energy efficiency and 21% higher than regular fixed-frequency units. It passes the national energy saving product certification and saves more running costs for customers.

TIPS

The IPLV considers the energy efficiency index when the unit runs in different loads, reflecting energy saving of air conditioners more objectively.

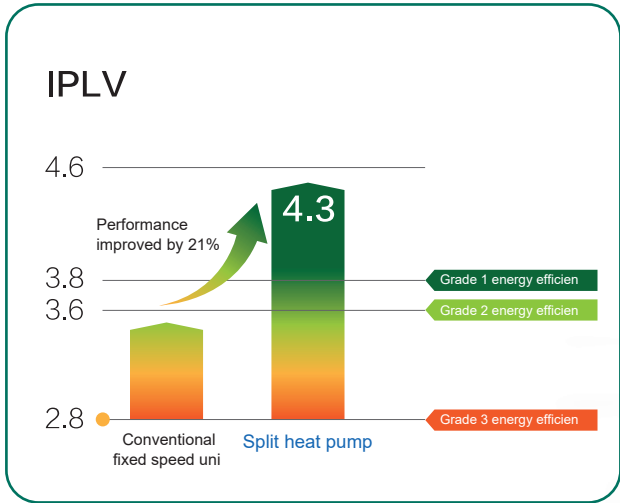

Heat Pump Heating for Lower Costs

Thanks to its higher comfort level, The floor heating system has become a common selection of high-end users. However, many users are deterred by higher running costs of electric boilers and wall-mounted gas boilers. Air to water split heat pump chiller can be directly connected to the floor for heating, with higher energy efficiency and 30% running costs of wall-mounted gas boilers. In addition, it features water-power separation, security, and no pollution. Therefore, Split heat pump has got the favor of more and more household customers.



Electric boiler

Large power consumption, easy to form water scale, electric heating tube prone to aging, potential leak of power supply



Wall-mounted gas boiler

Low combustion efficiency, failed to associate with the cooling part of air conditioner, potential leak of toxic gas, explosion risk

Cost	Split heat pump	Wall-mounted Gas Boiler
Heating area	100 m ²	
Unit load	80 W/m ²	
Heating duration	90 days * 24 h/day	
Total heating load	17,280 kW	
Energy form	Power	Gas
Average energy efficiency	4.3	0.93
Energy consumption	4018 kWh	1950 m ³
Unit price of energy	0.5 yuan/kWh	3 yuan/m ³
Annual cost	\$309	\$900

Note: The unit price of energy listed in the table is the average price of peak power and valley power in a day. The actual unit price of energy prevails locally.

Clean

Full-effect Purification for Clean Air

TICA adopts the air conditioning + purification + fresh air system to remove hazardous substances such as PM2.5, formaldehyde, and allergens and deodorize air, providing you with a clean indoor environment.



Multi-tier purification

The air conditioner is equipped with the residential-specific purifying fan coil unit, not only providing perfect silent effect but also configuring an air return purifier to effectively remove hazardous substances such as PM2.5 and formaldehyde.

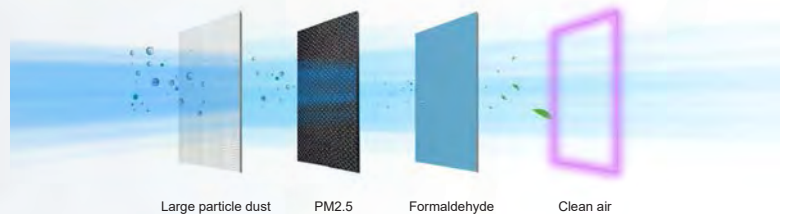

Physically Absorbing PM2.5 for Zero Ozone

96% efficiency for filtering PM2.5 (circulated for 120 minutes)

The exclusive electrostatic technology keeps electrostatic discharge on the filter material for a long term, 10 years at most
The 100% fiber material is green and moisture-resistant

Chemically Removing Formaldehyde

90% efficiency for filtering formaldehyde (circulated for 60 minutes)

The exclusive technology of chemically removing formaldehyde distributes capturing medicaments on the surface of filter layer evenly, implementing fast reaction with the aldehyde group.
The technology is secure and highly-efficient without the secondary release problem caused by excessive absorption of aldehyde group.

Fresh Air System, Supplying Forest Oxygen at Home

Scared to live in the newly decorated house due to high formaldehyde content?

Scared to smoke at home for fear that passive smoking does harm to kids and elders?

Hard to breathe because the air is stuffy with windows closed for a long term in winter?

Feel the room smell bad at night?

TICA professional household fresh air system increases the oxygen in your home!



- It integrates fresh air, air discharge, haze removal, and heat recovery. Fresh air filters PM2.5 at 95% efficiency for the first time. Dirty air is discharged while fresh air is supplied, which keeps air fresh indoors all the time.
- An intelligent control system is configured to display the concentration of PM2.5, formaldehyde, carbon dioxide, etc. in real time, making good air visible.

Refrigerant for Low-Carbon Living

R410A is an internationally-recognized environment-friendly refrigerant. It is stable, nontoxic, high-performance, chlorine-free, and non-destructive for ozone layer. In addition, the unit is driven by clean power energy, without the need of coal, oil, or gas consumption, releasing no hazardous gas or waste material. The clean and low-carbon refrigerant leads a healthy life.



Peace of Mind

Multi-tier Anti-freezing for More Secure Water System

The unit implements anti-freezing detection based on the water flow, water temperature, and refrigerant temperature and provides three-tier anti-freezing procedures to prevent local freezing of water pipelines in winter. In addition, the unit adopts a separated structure to install the water system indoors, offering higher anti-freezing protection and more peace of mind.



Water pumping



Heating



Electric heating

Separated structure brings you peace of mind

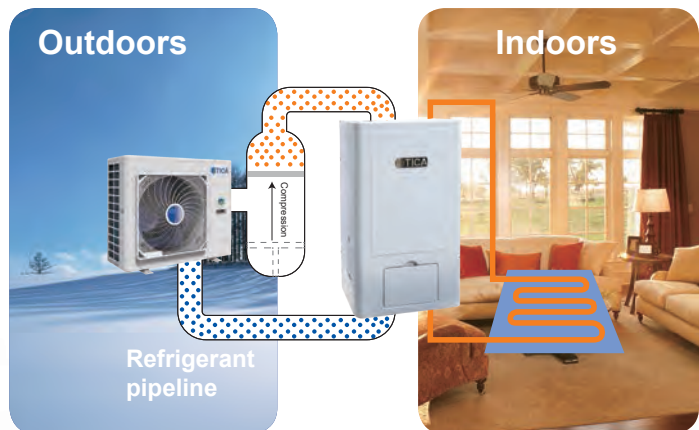

Fast Defrosting for Efficient Heat

Intelligent Defrosting



The unit intelligently determines whether to defrost based on the outdoor environment temperature and running status, to implement defrosting when frost exists and heating when frost does not exist, prevent mistaken defrosting, and improve heating efficiency to the maximum extent.

Powerful Defrosting



In severe conditions such as high humidity and low environment temperature, the unit automatically regulates to optimize defrosting effect, enhance heat exchange efficiency, and actively improve efficiency through powerful defrosting.

Comprehensive Security Protection for More Reliable Unit Running

The unit provides various hardware protection and software protection for control functions, to forecast faults timely and regulate running status for unit reliability.



Problem forecast

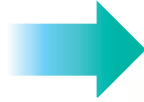

Running regulation



Security protection



Power supply protection

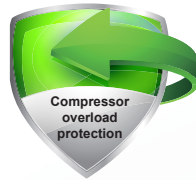

Compressor overload protection



Protection of too low outlet water temperature



Discharge high pressure protection



Protection of too high outlet water temperature



Low water flow protection



Fan overload protection



Discharge high temperature protection



Suction low pressure protection

Mini Body for More Flexible Installation



Single-fan design

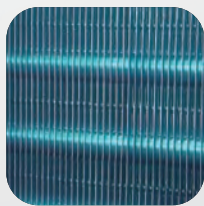

Compact high-quality efficient heat exchanger design

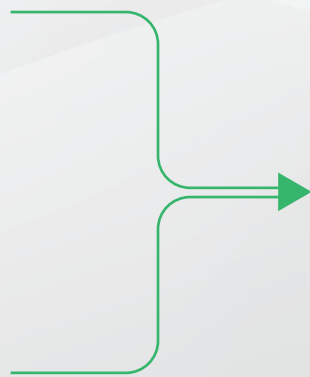

The small body carries large capabilities, breaking the complex space pattern. The unit body is only 850 mm high, convenient for installing in narrow space such as bay window, more flexible, and more fashionable

Intelligence

Varieties of Control

Air to water split heat pump chiller is equipped with a full-touch LCD controller to easily implement integrated control of air conditioning and floor heating

Operating mode



Fan coil cooling



Fan coil heating



Floor heating



Floor heat preservation

Regular function



Outdoor environment Temperature display



Time, date, and week display



Room temperature setting and display



Scheduled power-on/off



Automatic startup upon power recovery



Ultra quiet operation



Powerful defrosting



Error check



Password setting

Integrated Design for Worry-Free Operation

Adopting integrated design, the unit integrates water system accessories into the IDU and incorporates moving parts of the water system into the unified control of unit program. Such design not only reduces the working hours and expenses of field installation, but also improves reliability of the whole system.



Expansion tank



Safety valve



Flow switch



Water pump



Automatic discharge valve



Pressure gauge



ODU



IDU

Integrated control

Smart Home

The unit provides standard RS485 communication interfaces and Modbus communication protocol to easily access the third-party building automation system and smart home central control system.



Specification

Type		Wall-mounted			Ceiling		
Model		TSCA/I120FHL	TSCA/I140FHL	TSCA/I160FHL	TSCA/I120FHLN	TSCA/I140FHLN	TSCA/I160FHLN
ODU		TSCA120FHL	TSCA140FHL	TSCA160FHL	TSCA120FHL	TSCA140FHL	TSCA160FHL
IDU		TSCI120FHL	TSCI140FHL	TSCI160FHL	TSCI120FHLN	TSCI140FHLN	TSCI160FHLN
Heating capacity 1	Nominal heating capacity (kW)	12.5	14.2	16	12.5	14.2	16
	Rated power input (kW)	3.2	3.74	4.26	3.2	3.74	4.26
	COP _h (kW/kW)	3.91	3.8	3.76	3.91	3.8	3.76
Cooling capacity 1	Nominal cooling capacity (kW)	12	13.5	14.5	12	13.5	14.5
	Rated power input (kW)	4.24	5.01	5.56	4.24	5.01	5.56
	EER	2.83	2.69	2.61	2.83	2.69	2.61
Seasonal space heating energy efficiency class	LWT at 35°C	A+++					
	LWT at 55°C	A++					
SCOP	LWT at 35°C	4.65	4.6	4.52	4.65	4.6	4.52
	LWT at 55°C	3.45	3.4	3.31	3.45	3.4	3.31
Circulating water flow (m ³ /h)		2.06	2.41	2.75	2.06	2.41	2.75
Pump type		Variable frequency canned pump (Optional)					
Power supply		220-240V ~50Hz					
Maximum total power (kW)	ODU	7					
	IDU	0.3					
Maximum operating current (A)	ODU	35					
	IDU	1.36					
Applicable ambient temperature (°C)	Cooling	-15~55					
	Heating	-25~48					
Refrigerant/Charge quantity		R410A/3.05kg					
Sound power level(dB(A))ODU		67	69	70	67	69	70
Sound power level(dB(A))IDU		45	45	45	45	45	45
Unit external lift (mH ₂ O)		9.5	8	6.5	9.7	8.5	7.5
IP rating		IPX4, and applies to outdoor applications					
Refrigerant pipeline connection	Gas/liquid pipe diameter (mm)	φ19.05/φ9.52					
	Connection mode	Pipe socket					
Circulating water pipe connection	Water inlet/outlet pipe diameter	DN32					
	Connection mode	External thread (R 1-1/4')					
Net weight (kg)	ODU	96	96	96	96	96	96
	IDU	53	53	53	53	53	53
Dimensions L*W*H	ODU	980*420*840					
	IDU	520*245*892			1000*500*220		

Notes:

1. Nominal cooling test conditions: The water outlet temperature is 7°C and the outdoor dry bulb temperature is 35°C.
2. Due to the continuous improvement and innovation of TICA products, the product models, parameters and performance in this document are subject to changes without prior notice. The parameters indicated on the nameplate should prevail.
3. Please refer to the maximum total power and maximum operating current during power distribution.
4. The ODU has been charged with refrigerant.



Modular Inverter Air-cooled Scroll Chiller

CE



Nomenclature

Modular Inverter Air-cooled Scroll Chiller

TCAV 065 B HE

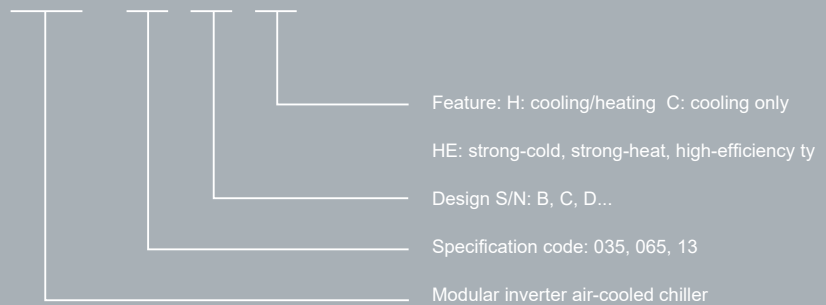



TICA modular unit represents **two decades of technological capability accumulation**

1st-generation modular unit successfully developed



1999

2002



1st-generation scroll modular unit unveiled

Industry leading 2nd-generation process modular unit



2004

2008



Ecological 3rd-generation N series R410A unit successfully developed

Energy saving 4th-generation G series efficient modular unit unveiled



2013



Modular Inverter Air-cooled Scroll Chiller

V-FORCE full-operating
condition inverter
Upgraded 7th-generation units, leading
an energy saving revolution

Extensive lineup

6th-generation X series units unveiled
Solutions to meet special process and
sanitary conditions, normal indoor use,
cooling only, low temperature and strong
heat, four-pipe, full heat recovery

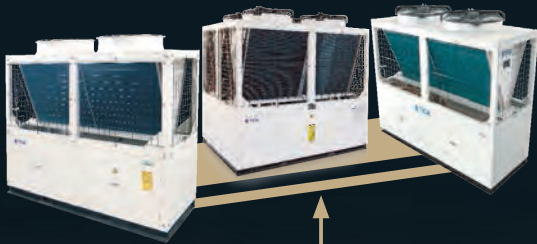

2014

2016-2019

2020



Targeted marketing

5th-generation H/J
series modular units
Unparalleled comfort/processing



Cases

Common occasions

Quiet and comfortable/heating at low temperature/full heat recovery

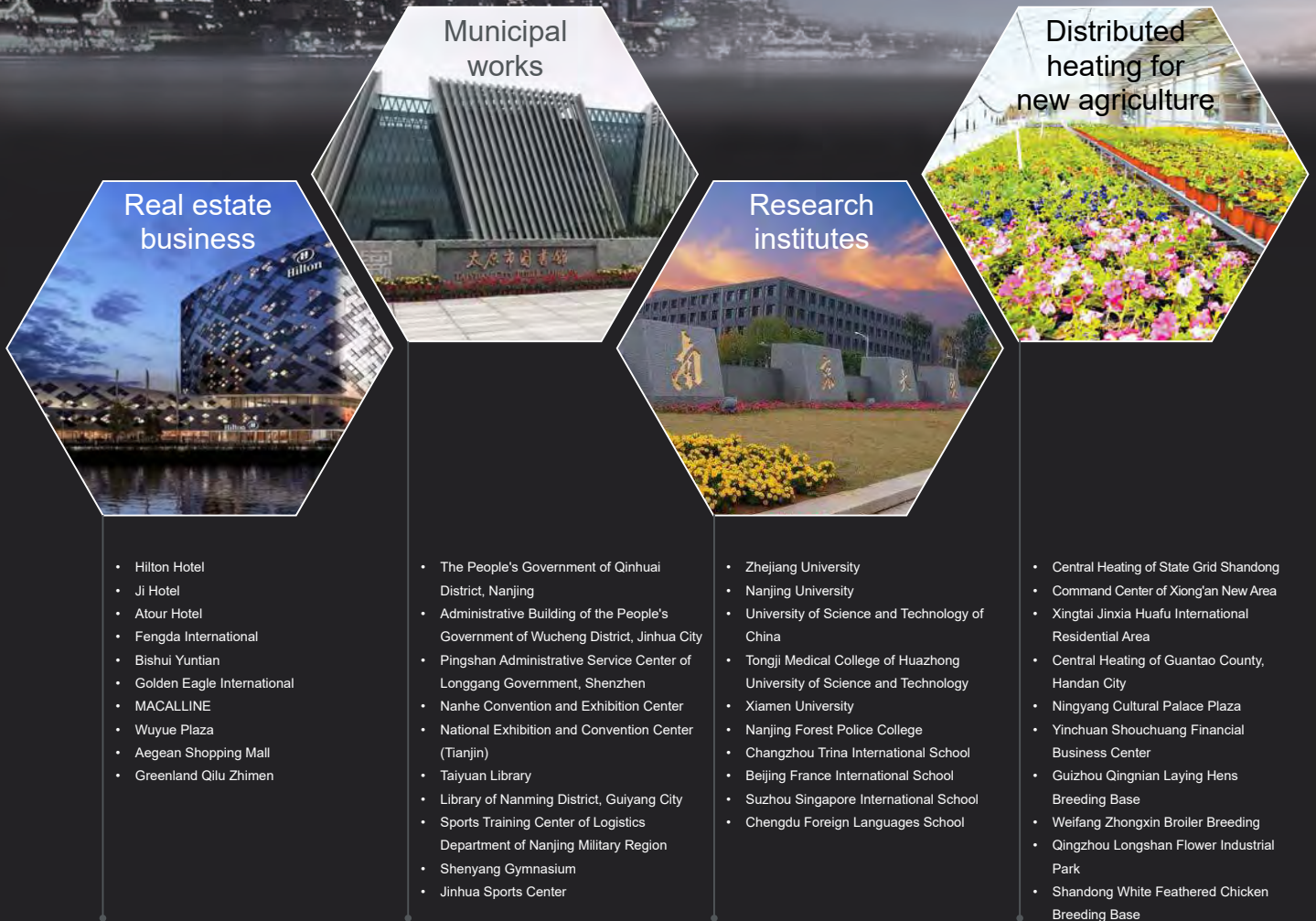

Process application

Industrial temperature control/cooling only/process cooling

Electronic purification



Laboratory test



Health care



Pharmaceutical industry



- Huoshenshan Hospital
- Affiliated Hospital of Putian University
- Uzbekistan Mobile Cabin Hospital
- Drum Tower Hospital
- Nanjing General Hospital of People's Liberation Army
- The First People's Hospital of Zhengzhou City
- Wuhan Children's Hospital
- Xi'an No. 3 Hospital
- The First Affiliated Hospital of Xi'an Jiaotong University
- The First Affiliated Hospital of School of Medicine of Zhejiang University

- Dongshan Precision
- Goertek
- Foxconn
- Holitech
- Compal Electronics
- AAC Technologies
- OFILM
- Omron
- Risen Energy
- Silan

- Double Crane Pharmaceutical
- Sihuan Pharmaceutical
- CSPC
- Livzon Pharm
- Jingxin Pharmaceutical
- Kangmei Pharmaceutical
- Tasly Pharmaceutical
- Bright Future Pharmaceutical Laboratories
- Kanion Pharmaceutical
- Xianju Pharmaceutical

- Institute of Biophysics, Chinese Academy of Sciences
- Hefei General Electrical and Mechanical Product Testing Institute
- Shenzhen Academy of Metrology & Quality Inspection
- Henan Institute of Metrology
- Lianyungang Drug Administration
- Ningxia Food and Drug Administration
- Changsha Center for Disease Control and Prevention
- DNA Testing of Nanjing Public Security Bureau
- Animal Research Center of Medical School of Nanjing University
- GTTC

Excellence in **All** Aspects

Operate under all conditions

Operate at -26°C to +55°C
Performance improved by 20% at
extreme conditions

Full inverter energy saving

Dual grade-1 IPLV for cooling and heating
IPLV comprehensive energy
saving rate up to 26%

Various application scenarios

Solutions to meet normal indoor use, special
process and sanitary conditions, cooling only,
low temperature and strong heat, etc.
Full application scenario alternative



Simple but Stunning



Concise structure

- Full concealed design
- Four-way air return
- Ivory white coating

Simplified system

- Single compressor design
- Optimized refrigerant pipeline

User-friendly experience

- Full series compatibility of modular unit
- Easy-to-use control panel (optional), one-key operation
- Data control, convenient after-sales service

Operate under all conditions

With years of experience in developing and designing process air conditioners, TICA has successfully integrated EVI and full inverter technologies and made a breakthrough in the operation of modular units.

Operating temperature in cooling mode: -20 to +55°C
 Operating temperature in heating mode: -26 to +55°C
 Performance improved by 20% at extreme conditions



1 Dynamic control of condensation pressure

Efficient inverter fan and 15%-100% stepless capacity control to match changes in the system pressure in real time.



2 Inverter EVI technology

Inverter adjustment under partial load ensures efficient operation
 EVI technology ensures strong cold and strong heat at extreme conditions.



3 Self-developed drive control program

German stepless sine-wave permanent magnet motor driving technology provides computing at 8000 times per second and double filtering to ensure that power disruption is removed at all frequencies.

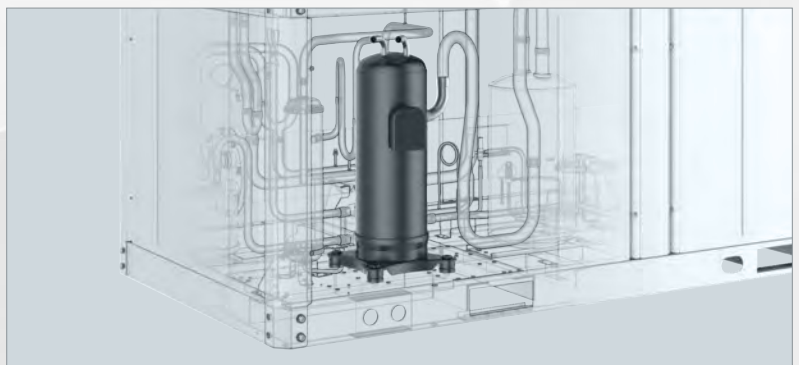

Modular Inverter Air-cooled Scroll Chiller

Full inverter energy saving

V-FORCE modular units use full inverter design so that the partial load efficiency is greatly enhanced

With patented control technology, multiple units are able to operate at the same time in a stable, efficient and balanced manner.

Reaching the national EEI level 1 in cooling and heating mode

IPLV is above **4.55** in cooling mode exceeding the national EEI level 1 (4.0)

IPLV is above **3.10** in heating mode meeting the national EEI level 1 for heating of the new national standard

*The cooling performance complies with GB 19577-2015

*The heating performance complies with GB 37480-2019



National EEI level 1

Energy Efficiency Curves of V-FORCE/Average Modular Units During Operation

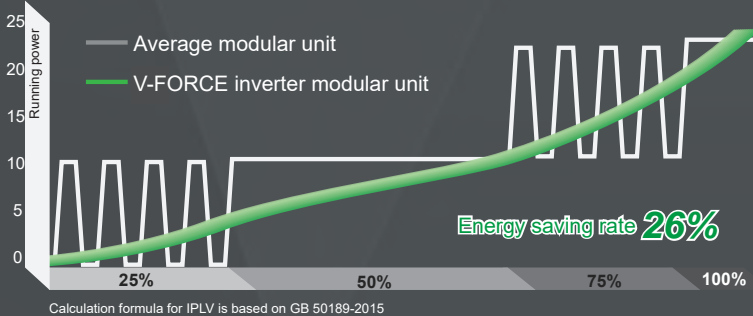

Inverter operation and accurate output

The unit is equipped with a large-capacity inverter compressor that supports 15%-100% stepless regulation. The unit has a smooth performance curve. In addition, it performs well under partial load and the compressor does not start or stop frequently.

Energy Efficiency Curves of Variable and Fixed Speed Modular Units During Operation (Five Sets)

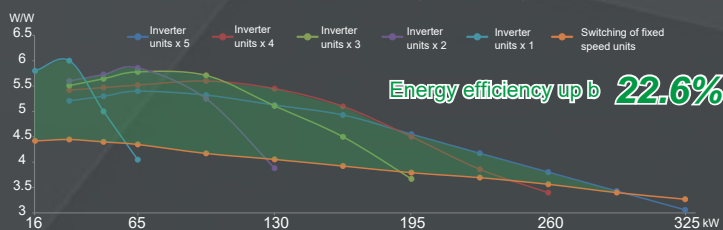

Balanced control to ensure energy efficiency

Partial load operation prioritized

When multiple modules are combined, the frequency of each compressor is intelligently controlled, so that the system operates in an energy-efficient area in a balanced manner.

Various application scenarios

Comfort

Silent and environmentally friendly
Extremely comfortable



The noise can be lowered by 6-10 dB(A) in silent mode
The noise can be as low as 50 dB(A) in partial load

Process

Perennial cooling
Stable operation

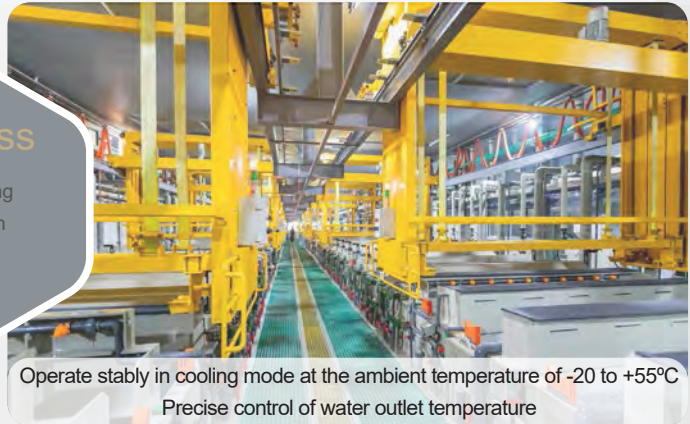

Operate stably in cooling mode at the ambient temperature of -20 to +55°C
Precise control of water outlet temperature

Strong heat

Low temperature and strong heat
EVI and enhanced efficiency



Heat at even -26°C (water outlet temperature at 40°C)
The water outlet temperature can reach 55°C
(when the ambient temperature is above 0°C)



Simple but Stunning

Concise structure

- ◆ Vulnerable parts fully concealed to facilitate installation
- ◆ Four-way air return and 45% more windward area to ensure more efficient heat exchange and reliable structure
- ◆ TICA classical "ivory white" coated metal sheet framework

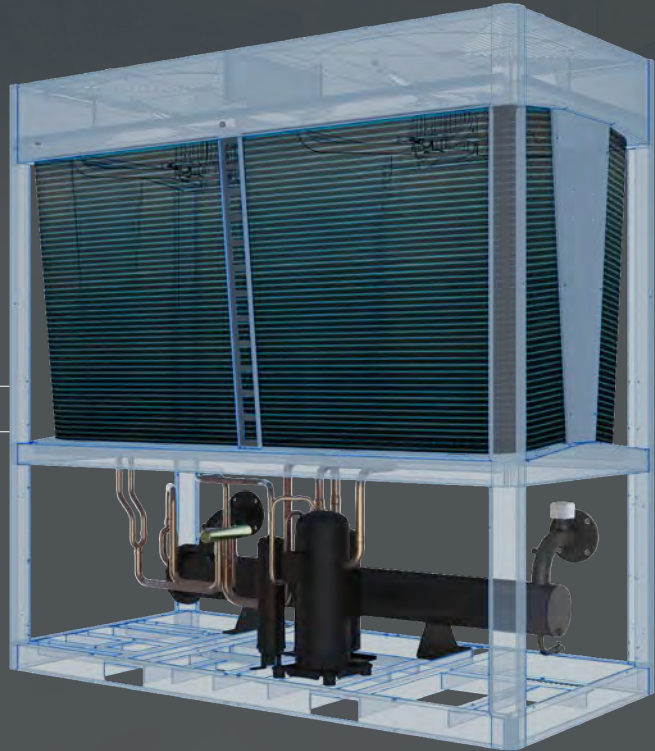

Simplified system

- ◆ Creative single compressor design featuring inverter and EVI technologies
- ◆ Optimized refrigerant pipeline to reduce welding costs

User-friendly experience

- ◆ Installation – full series compatibility of modular unit
- ◆ Usage – easy-to-use control panel (optional), one-key operation
- ◆ After-sales service – standard memory module and ten-year data management



Technical Specification

Specification

Model			TCAV035BHE	TCAV065BHE
Nominal cooling	Cooling capacity	kW	33.5	65.0
	Power consumption	kW	12.0	21.2
	COP	W/W	2.79	3.06
	IPLV	W/W	4.60	4.55
Nominal heating 1	Heating capacity	kW	24.0	48.0
	Power consumption	kW	10.2	20.5
	COP	W/W	2.35	2.34
	IPLV	W/W	3.20	3.10
Nominal heating 2	Heating capacity	kW	34.0	75.0
	Power consumption	kW	10.5	23.4
	COP	W/W	3.24	3.20
Power supply	–	380 V 3N–50 Hz		
Water flo	m ³ /h	5.76	11.2	
Water resistance	kPa	30	45	
Water inlet and outlet pipe connection type	–	DN40 external thread connection	DN65 flange connectio	
Operating mode	–	Automatic operation controlled by microcomputers		
Compressor	Type	–	Scroll type DC inverter EVI	
	Qty	Set	1	1
Fan	Type	–	DC inverter low-noise axial flow fa	
	Air flo	m ³ /h	13000	26000
	Qty	Set	1	2
Refrigerant	Type	–	R410A	
External Dimensions (Length * Width * Height)		mm	1170×846×1694	2000×950×2020
Weight	Net weight	kg	285	600
	Operating weight		300	660
Noise		dB(A)	50 - 61	50 - 67
Maximum total power		kW	20	31.5
Maximum operating current		A	30.5	50

- ★ Notes:
- The nominal cooling capacity and nominal cooling consumption power are tested at the rated water flo , water outlet temperature of 7°C, and outdoor dry-bulb temperature of 35°C.
The nominal heating capacity 1 is tested at the rated water flo , water outlet temperature of 41°C, and outdoor dry-bulb temperature of -12°C and wet-bulb temperature of -14°C.
The nominal heating capacity 2 is tested at the rated water flo , water outlet temperature of 45°C, and outdoor dry-bulb temperature of 7°C and wet-bulb temperature of 6°C.
 - About 6% loss caused by system pipelines, water pumps, valves, and dirt after unit installation shall be considered for the cooling (heating) capacity in actual applications.
 - Parameters listed in the above tables are for a single module. Up to 16 modules can be used together.
 - The control accessory box needs to be purchased separately, which contains the wired controller, wired controller communication cable, user manual, temperature sensor, etc. The box content may change. Please refer to the actual factory configurations

Operating Range

Ambient temperature range in cooling mode	°C	-20 - 55
Ambient temperature range in heating mode	°C	-26 - 55
Cooling return water temperature	°C	10 - 25
Cooling water outlet temperature	°C	5 - 20
Heating return water temperature	°C	25 - 50
Heating water outlet temperature	°C	30 - 55

Unit Selection Parameters Correction

Cooling Capacity Table

TCAV035BHE

Water outlet temperature °C	Ambient Temperature (°C)																													
	55		52		48		44		40		35		30		25		15		5		0		-5		-10		-15		-20	
	Capacity (kW)	Power (kW)	Capacity (kW)	Power (kW)	Capacity (kW)	Power (kW)	Capacity (kW)	Power (kW)	Capacity (kW)	Power (kW)	Capacity (kW)	Power (kW)	Capacity (kW)	Power (kW)	Capacity (kW)	Power (kW)	Capacity (kW)	Power (kW)	Capacity (kW)	Power (kW)	Capacity (kW)	Power (kW)	Capacity (kW)	Power (kW)	Capacity (kW)	Power (kW)	Capacity (kW)	Power (kW)	Capacity (kW)	Power (kW)
5	6.9	5.8	12.0	9.3	16.1	10.6	25.8	12.5	30.8	13.5	32.2	11.8	32.8	11.0	34.5	10.5	34.3	9.0	36.1	8.6	36.3	8.6	36.4	8.4	34.2	7.9	36.4	8.0	38.6	8.0
7	7.2	6.0	12.6	9.3	18.3	10.9	26.8	12.6	32.1	13.5	33.5	12.0	34.7	11.1	36.3	10.6	36.0	9.1	37.2	8.6	37.3	8.7	37.4	8.6	35.7	8.0	37.9	8.2	40.1	8.3
9	7.8	6.2	13.6	9.4	20.5	11.2	27.8	12.7	33.4	13.6	35.4	12.2	36.6	11.2	38.1	10.6	37.8	9.1	38.2	8.7	38.3	8.8	38.3	8.8	37.1	8.2	39.4	8.4	41.6	8.7
12	8.4	6.5	15.3	9.6	22.8	11.5	29.3	12.8	35.3	13.6	38.4	12.5	39.4	11.4	40.8	10.7	40.3	9.2	39.7	8.7	39.8	8.8	39.8	8.9	39.3	8.4	41.6	8.8	43.9	9.1
15	9.5	6.8	18.0	9.8	25.0	11.8	30.8	13.0	37.2	13.7	41.3	12.8	42.3	11.6	43.4	10.8	42.9	9.3	41.3	8.8	41.3	8.7	41.3	9.0	41.5	8.6	43.8	9.1	46.1	9.6
20	11.0	7.1	22.7	10.2	29.9	12.1	35.0	13.1	43.0	13.9	44.6	13.2	47.0	11.8	48.8	10.9	48.1	9.5	44.4	8.9	44.3	9.0	44.3	9.1	45.8	9.0	48.2	9.8	50.6	10.6

TCAV065BHE

Water outlet temperature °C	Ambient Temperature (°C)																													
	55		52		48		44		40		35		30		25		15		5		0		-5		-10		-15		-20	
	Capacity (kW)	Power (kW)	Capacity (kW)	Power (kW)	Capacity (kW)	Power (kW)	Capacity (kW)	Power (kW)	Capacity (kW)	Power (kW)	Capacity (kW)	Power (kW)	Capacity (kW)	Power (kW)	Capacity (kW)	Power (kW)	Capacity (kW)	Power (kW)	Capacity (kW)	Power (kW)	Capacity (kW)	Power (kW)	Capacity (kW)	Power (kW)	Capacity (kW)	Power (kW)	Capacity (kW)	Power (kW)	Capacity (kW)	Power (kW)
5	12.1	10.9	23.2	16.4	31.2	18.8	50.0	22.0	58.1	23.1	62.5	20.9	63.6	19.5	67.0	18.6	66.5	16.0	70.1	15.2	70.3	14.8	70.6	14.4	66.4	14.0	70.7	14.1	74.9	14.2
7	12.8	10.9	24.4	16.5	35.5	19.3	52.0	22.2	60.5	23.2	65.0	21.2	67.3	19.7	70.4	18.7	69.9	16.1	72.1	15.3	72.3	14.9	72.5	14.5	69.2	14.2	73.5	14.5	77.8	14.7
9	13.8	11.1	26.4	16.6	39.9	19.9	53.9	22.4	62.9	23.2	68.8	21.5	71.0	19.9	73.9	18.8	73.2	16.2	74.1	15.3	74.2	15.0	74.4	14.6	72.0	14.5	76.4	14.9	80.8	15.3
12	15.5	11.2	29.6	16.9	44.2	20.4	56.8	22.6	66.4	23.4	74.5	22.0	76.5	20.1	79.1	18.9	78.3	16.3	77.1	15.5	77.2	15.1	77.3	14.7	76.2	14.8	80.7	15.5	85.1	16.2
15	18.3	11.5	35.0	17.3	48.5	20.9	59.8	22.9	70.0	23.5	80.2	22.6	82.1	20.4	84.3	19.1	83.3	16.5	80.1	15.6	80.1	15.2	80.1	14.9	80.5	15.2	85.0	16.1	89.5	17.0
20	23.0	12.0	44.0	18.0	58.0	21.3	68.0	23.1	81.0	23.9	86.5	23.2	91.3	20.9	94.7	19.3	93.4	16.8	86.1	15.8	86.0	15.5	85.9	15.2	88.9	16.0	93.6	17.3	98.2	18.7

Heating Capacity Table

TCAV035BHE

Water outlet temperature °C	Ambient Temperature (°C)																													
	-26		-20		-15		-10		-5		0		7		10		15		20		25		30		35		48		55	
	Capacity (kW)	Power (kW)	Capacity (kW)	Power (kW)	Capacity (kW)	Power (kW)	Capacity (kW)	Power (kW)	Capacity (kW)	Power (kW)	Capacity (kW)	Power (kW)	Capacity (kW)	Power (kW)	Capacity (kW)	Power (kW)	Capacity (kW)	Power (kW)	Capacity (kW)	Power (kW)	Capacity (kW)	Power (kW)	Capacity (kW)	Power (kW)	Capacity (kW)	Power (kW)	Capacity (kW)	Power (kW)	Capacity (kW)	Power (kW)
30	16.0	8.1	20.0	8.7	24.0	9.2	26.9	9.0	30.5	9.0	34.0	8.5	35.7	8.5	40.0	8.8	40.5	9.0	40.1	7.8	39.8	6.7	42.9	6.4	46.1	6.5	49.0	5.9	51.0	6.1
35	15.9	9.0	19.8	9.1	23.7	9.7	26.9	9.9	30.1	10.1	33.0	9.3	34.3	9.0	39.2	9.1	40.4	9.1	40.1	7.9	39.7	6.7	42.8	6.4	46.0	6.5	49.0	5.6	51.0	5.8
40	15.5	10.2	19.6	9.7	23.4	10.8	26.9	11.0	30.3	11.2	32.8	10.1	33.6	9.5	38.9	10.0	40.4	10.4	39.0	9.1	37.5	7.9	40.4	7.6	43.3	7.7	43.5	6.7	45.5	6.9
45			19.3	11.6	22.6	11.9	26.3	12.1	29.9	12.3	32.2	11.2	34.0	10.5	38.5	11.1	40.4	11.6	39.5	9.4	38.6	7.3	41.6	7.0	44.5	7.1	44.8	6.2	46.8	6.4
50			19.2	13.3	21.8	13.5	25.7	13.5	29.5	13.4	31.8	12.2	32.4	11.6	38.2	12.2	40.3	12.9	38.4	10.7	36.5	8.5	39.3	8.2	42.1	8.3	42.1	8.1	44.1	8.3
55											31.3	12.0	32.0	11.1	38.0	12.6	40.3	14.1	37.8	11.9	35.4	9.6	38.1	9.4	35.4	9.5	36.2	7.2	37.0	7.3

TCAV065BHE

Water outlet temperature °C	Ambient Temperature (°C)																													
	-26		-20		-15		-10		-5		0		7		10		15		20		25		30		35		48		55	
	Capacity (kW)	Power (kW)	Capacity (kW)	Power (kW)	Capacity (kW)	Power (kW)	Capacity (kW)	Power (kW)	Capacity (kW)	Power (kW)	Capacity (kW)	Power (kW)	Capacity (kW)	Power (kW)	Capacity (kW)	Power (kW)	Capacity (kW)	Power (kW)	Capacity (kW)	Power (kW)	Capacity (kW)	Power (kW)	Capacity (kW)	Power (kW)	Capacity (kW)	Power (kW)	Capacity (kW)	Power (kW)	Capacity (kW)	Power (kW)
30	31.2	15.9	39.0	16.5	44.7	16.8	50.2	17.3	59.2	17.9	67.8	18.3	75.9	18.4	81.0	18.5	81.8	18.2	81.9	16.5	65.0	11.5	70.2	11.0	75.4	11.2	80.1	10.2	82.1	10.4
35	30.9	17.7	38.5	18.4	44.7	18.3	49.7	18.8	59.2	19.6	67.2	20.1	75.9	19.9	80.8	20.5	81.8	20.0	82.6	17.6	65.7	12.6	70.9	12.1	76.1	12.3	81.1	10.6	83.1	10.8
40	31.0	19.4	37.6	20.2	44.9	19.8	49.2	20.8	59.2	21.3	66.1	21.9	75.9	21.4	80.6	22.1	81.8	21.8	81.3	18.9	67.9	13.9	73.1	13.4	78.3	13.6	78.6	11.8	80.6	12.0
45			36.6	22.0	44.7	21.6	48.6	23.0	58.9	23.8	65.5	23.7	75.0	23.4	80.4	23.6	81.8	23.5	82.0	20.1	68.1	15.1	73.3	14.6	78.5	14.8	79.0	12.8	81.0	13.0
50					45.2	23.6	49.7	25.2	58.9	26.1	65.0	25.5	73.8	25.1	80.1	25.8	81.9	25.3	80.7	21.4	67.6	16.4	72.8	15.9	78.0	16.1	78.1	13.8	80.1	14.0
55											65.0	27.5	73.8	26.7	79.9	27.4	81.6	27.4	78.1	22.7	67.1	17.7	72.3	17.2	67.1	17.4	78.0	14.8	80.0	15.0

Unit Dimensions

TCAV035BHE

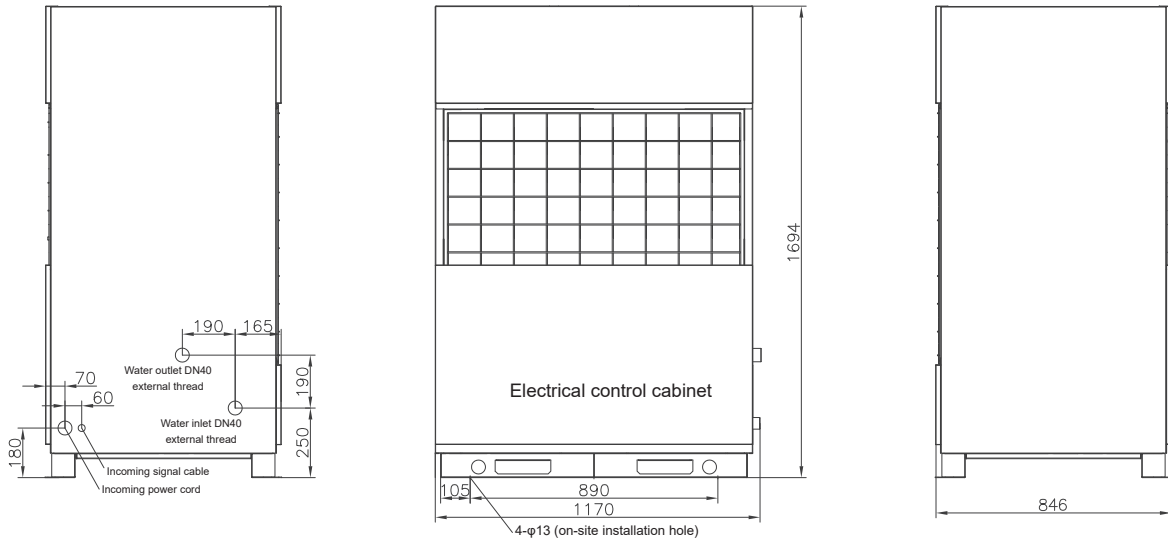

TCAV065BHE

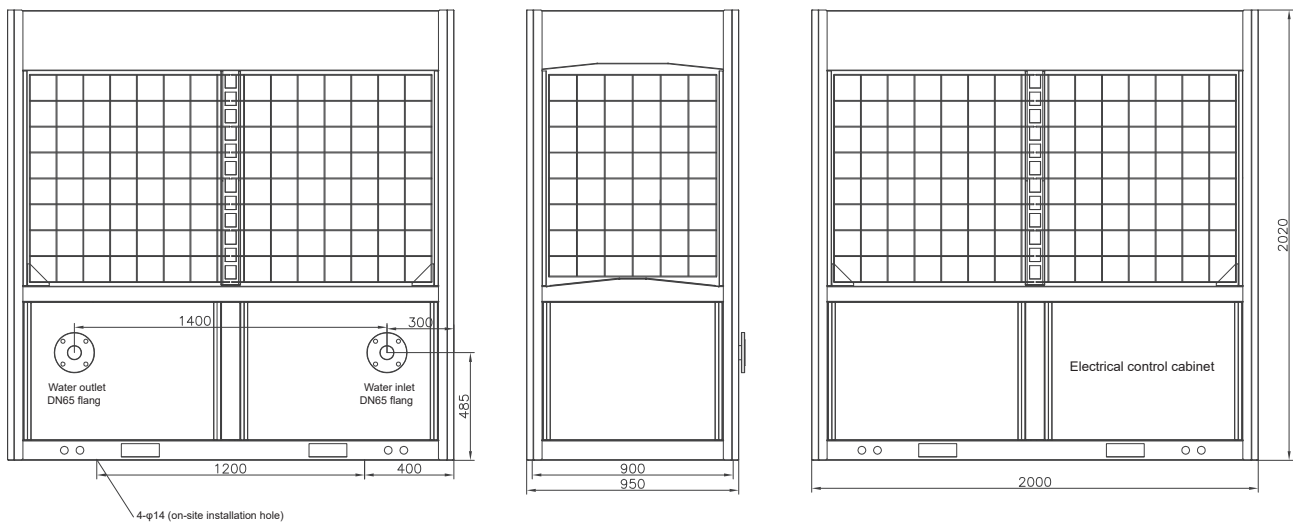

Modular Fixed Frequency Air-cooled Scroll Chiller

CE



Product Line

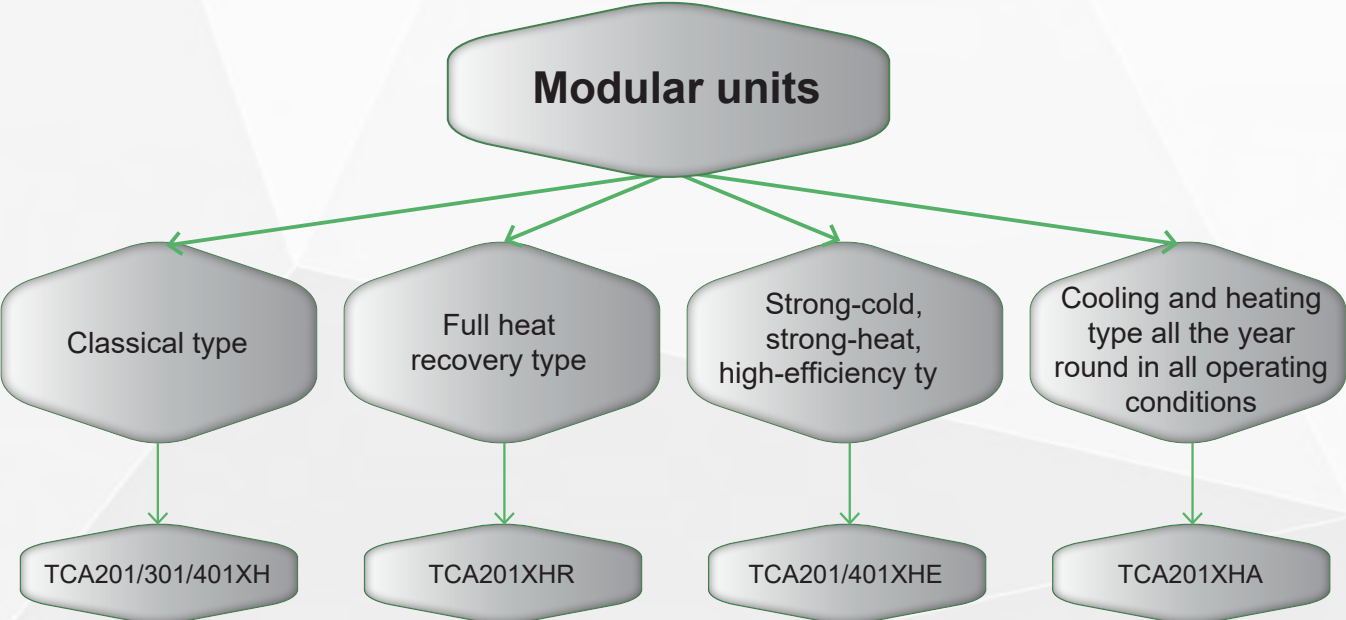

Classical Modular Chiller(TCA-X)

R410A CLASSICAL MODULAR UNIT

The new generation of X series environment-friendly modular air-cooled unit is based on 20 years of experience in R&D and design, which is greatly improved in aspects of the structure, system and microcomputer control technology, providing wider operation range of refrigeration and heating, and higher adaptability to applications with requirements on comfort and technology. There are basic modules of any combination available for different models, including 66 kW, 100 kW, 130 kW, and at most 16 modules can be connected in parallel, providing combination products of 66 kW ~ 2080 kW.

Excellent Capacity

Units of the same model or different models can be combined freely. Each group can combine up to 16 modules.

Free master Module Design

Any single unit can operate as the master once connected with the wired controller. It overcomes the problem that the whole system would fail to work properly when the fixed master unit malfunctions.

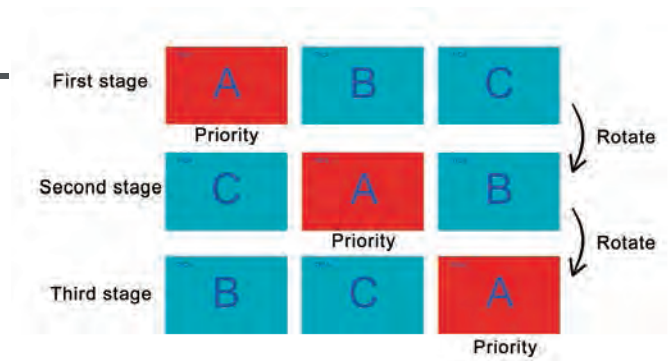

Intelligent Defrosting Technology, Non-stop When Defrosting

The unit control system can determine whether defrosting is necessary according to the ambient temperature in heating mode, evaporating temperature and running time; when defrosting conditions are met, the unit will automatically activate the defrosting program to complete defrosting within a short time and provide heating operation efficiency up to over 90% , ensuring the optimum heating capacity and high EER.

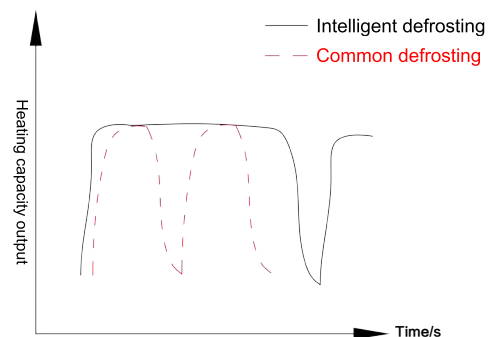

Intelligent Air Volume Regulation

The shared duct system is adopted to greatly expand the operating range. The single-module unit can automatically increase or reduce fans based on the ambient temperature to achieve optimal matching between air volume and load and deliver outstanding performance.



Intelligent Energy Regulation Technology

Unique intelligent energy regulation technology in multi-module combination ensures that each module loads or unloads a refrigerant circuit before loading or unloading other refrigerant circuits in the single module, thereby providing higher efficiency, stability and IPLV.



Widely Operation Range

Low temperature cooling
5°C~48°C

High temperature heating
-15°C~48°C

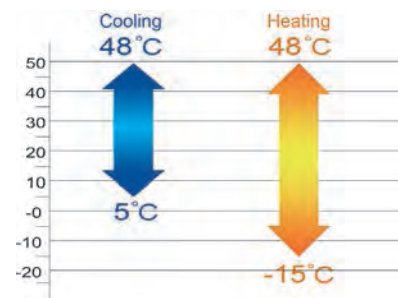

Compact Design And Less Occupied Area

Unique and compact structure results in small size and occupied area, significant reductions in installation space and cost; the unit is compact and easy to install. A 130KW unit covers floor space of only 2.42m², a 50% reduction compared to its equivalents.

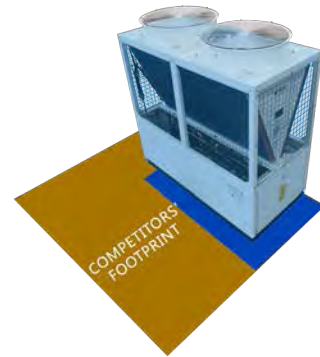

Famous Hermetic Scroll Compressor

Unit adopt famous brand hermetic scroll compressor, which is high-efficient, energy saving and operates stably, with low noise, slight vibration and long service life.

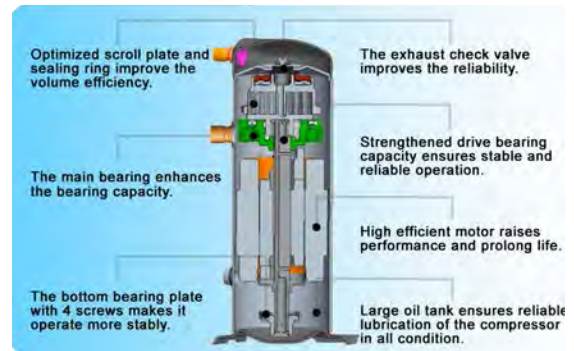

V-Shaped Condenser

The v-shaped condenser has used an integral reinforcing metal frame, internal thread and triple anti-frosting features (patented design of open-window hydrophilic aluminum foil + bottom elevated + one-way valve), providing higher structural stability and corrosion resistance; with heat exchange efficiency improved through full use of heat exchange area, low tendency to dust accumulation and frosting in winter, low loss of pressure, smoother drainage and higher reliability.

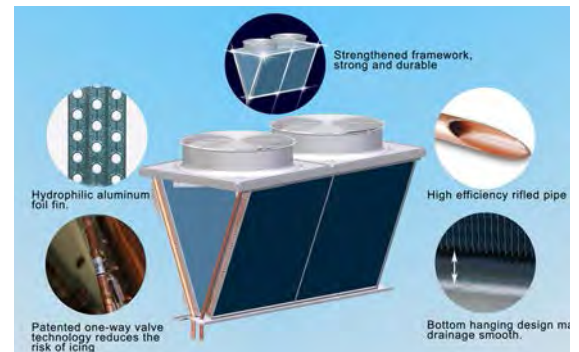

Efficient Shell And Tube Heat Exchanger

The waterside efficient shell and internal thread heat exchanger is of helical baffle type, with better heat transfer performance and higher resistance to freezing than plate heat exchanger, lower water resistance and lower requirements for water quality.

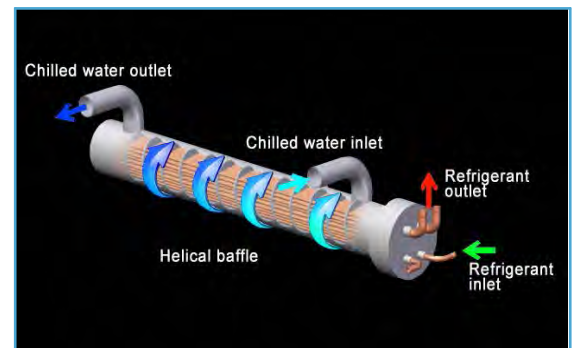

Saw-shaped Impeller

Compared to plastic impellers, the saw-shaped impellers provide large air volume, high durability and high air supply efficiency with low noise.



High Precision Electronic Expansion Valve

The electronic expansion valve achieves 480 regulating range, supplemented by TICA's patented precision throttle control technology to realize dynamic matching in refrigerating system, fully improve the optimum efficiency of each component and ensure the optimum condition of system operation pressure and temperature.

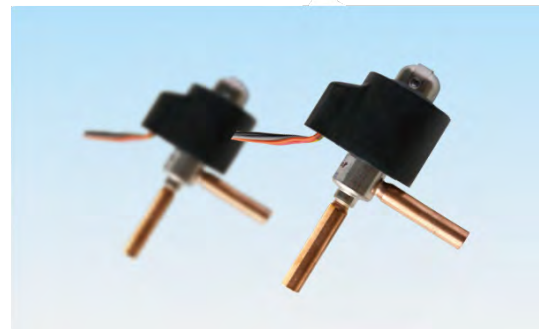

Self-developed Microcomputer Control Panel

TCA control panel is fully upgraded based on original control panels with years of experience in R&D and design, which combines more functions including phase sequence detection, current detection, RS-485 communication interface, delivering stronger performance, utility, standardization, convenience and universality. The USB interface is also provided to facilitate later-stage maintenance and upgrade of control function. The panel is supplemented by TICA developed control program which offers full operation control and multiple safety protection functions.



Multiple Protection Functions, Providing Safety And Stability

The unit has multiple safety protection functions which ensure safety and stable operation of the unit and systems. The water flow switch and multiple anti-freezing program designs protect the unit and systems in an all-round way.

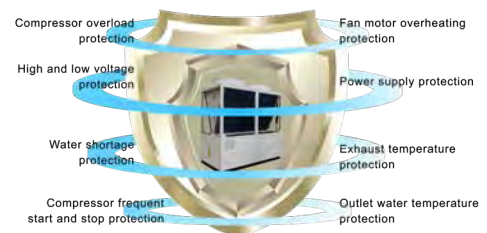

Specifications

Specifications - Total Heat Recovery Type (TCA-XHR/1)
380V-3N-50Hz/460V-3N-60Hz/380V-3N-60Hz

Model			TCA201XH	TCA301XH	TCA401XH	TCA201XC	TCA401XC	TCA301XC/B	TCA401XC/A
Power supply		V-ph-Hz	380-3-50	380-3-50	380-3-50	380-3-50	380-3-50	460-3-60	380-3-60
Cooling	Cooling capacity	kW	66	100	130	66	130	100	130
	Cooling power input	kW	21.29	32.25	41.9	21.29	41.9	32.25	41.9
	Cooling current	A	40.3	59.9	75.5	37.9	75.5	54.1	73.5
Heating	Heating capacity	kW	70	110	140	/	/	/	/
	Heating power input	kW	21.85	34.37	43.7	/	/	/	/
	Heating current	A	41.4	61.9	76.5	/	/	/	/
Maximum power input		kW	30.2	43.6	57.6	30.2	57.6	42	55
Maximum input current		A	50	80	100	50	100	65	100
Starting current		A	140	125	266.1	172	266.1	185.6	300
Energy regulation		%	0-50-100	0-50-100	0-50-100	0-50-100	0-50-100	0-50-100	0-50-100
Compressor	Type	-	Hermetic scroll compressor						
	Brand	-	Emerson	Emerson	Emerson	Emerson	Emerson	Emerson	Emerson
	Qty	-	2	4	2	2	2	2	2
Evaporator	Type	-	High-efficiency shell-and-tube heat exchange						
	Water flo	m ³ /h	11.4	17.2	22.4	11.4	22.4	17.2	22.4
	Water pressure drop	kPa	45	30	45	45	45	50	60
	Connection pipe dimension	-	DN65(Flange)						
Fan	Qty	-	2	2	2	2	2	2	2
	Air flo	m ³ /h	28000	43000	48000	28000	48000	36000	47000
	Current	A	2.35	4.5	5.3	2.35	5.3	3.3	5
	Power	kW	1.13	1.8	2.2	1.13	2.2	1.5	2
Unit dimensions (L*W*H)		mm	2200×860×2000	2200×1100×2205	2200×1100×2205	2200×860×2000	2200×1100×2205	2200×1100×2205	2200×1100×2205
Packaging dimensions (L*W*H)		mm	2260×920×2000	2260×1160×2205	2260×1160×2205	2260×920×2000	2260×1160×2205	2260×1160×2205	2260×1160×2205
Net weight		kg	580	850	900	570	850	820	850
Operating weight		kg	640	930	1000	630	950	900	950
Refrigerant	Type	-	R410A	R410A	R410A	R410A	R410A	R410A	R410A

Note:

- The nominal cooling capacity and nominal cooling input power are tested at the rated water flow, water outlet temperature of 7°C, and outdoor dry-bulb temperature of 35°C.
The nominal heating capacity is tested at the rated water flow, water outlet temperature of 45°C, outdoor dry-bulb temperature of 7°C or outdoor wet-bulb temperature of 6°C.
- The operating range is 5°C to 48°C for cooling and -15°C to 48°C for heating. If the unit needs to run in cooling mode at an ambient temperature lower than 5°C, please contact TICA factory.
- As a separate item, control accessory box contains a wired controller, a wired controller communication cable, user manual, and temperature sensor. The configuration is subject to changes, so please refer to actual unit upon deliver.
- The specifications above are based on a single module. Multiple modules can be used in combination. A maximum of 16 modules can be combined.
- About 6% loss caused by system pipelines, water pumps, valves, and dirt after unit installation shall be considered for the cooling (heating) capacity in actual application.

Total Heat Recovery Modular Unit (TCA-XHR/1)

TICA's total heat recovery modular air-cooled chiller (heat pump) unit uses the environment-friendly refrigerant R410A and combines the features of TICA air-cooled chiller (heat pump) unit and air-source heat pump water heater unit. It has five modes: A/C cooling, A/C heating, heat recovery, heat pump water heating, A/C heating + heat pump water heating, widely applied in places requiring central air conditioning and water heating, such as hotels, schools, restaurants, hospitals, villas, bath centers.

Free Domestic Hot Water

In the A/C cooling mode, the unit can recover waste heat and provide free domestic hot water up to 55°C. The unit replaces the boiler to meet the user needs for hot water, saves initial investment, eliminates the need for machine room, and saves the building area and energy for environmental protection.



Footprint

A single module covers a floor area of only 1.89 m² which is the smallest in the industry, leaving larger valuable space for customers. The unit can substitute the boiler, eliminates the need for machine room, and saves initial investment and building area.

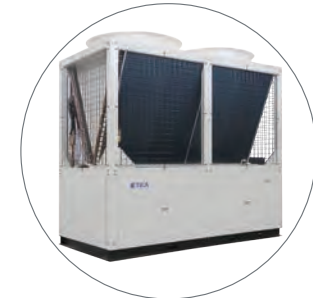

Complete Functions

The compact structural design does not impair strong functions and five modes are more widely applied, including refrigeration, heating, heat recovery, heat pump water heating, A/C heating + heat pump water heating.



Efficient Components Providing Higher Efficiency

The unit employs efficient shell and tube heat exchanger, fan, and heat recovery unit, with optimized pipeline design, providing comprehensive energy efficiency up to 8.24 under conditions of cooling + heat recovery.



Total Heat Recovery Operation Mode

The full heat recovery air-cooled chiller uses R410A refrigerant and combines the characteristics of the Tianjia modular unit and the air source heat pump hot water unit, including five modes: Cooling mode, Heating mode, Cooling + DHW, Domestic Hot water, Heating + DHW, Used in hotels, schools, restaurants, hospitals, villas, bathing centers and other places that need to provide air conditioning and hot water.

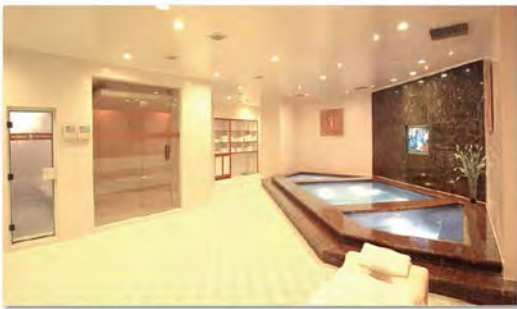

Green Technology

Refrigeration total heat recovery is to use 100% of the heat of the condenser in the refrigeration cycle to prepare hot water, realize the reuse of waste heat, reduce the thermal pollution caused by the condensation heat to the environment, and reduce the power consumption of the cooling fan and the noise of the unit. In addition, this chiller can run the heat pump hot water mode alone in winter, and it can meet the demand for hot water in winter without adding other hot water equipment, which greatly reduces the initial investment of engineering equipment.

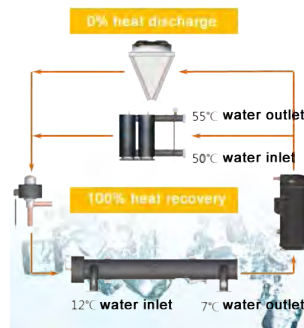

High efficiency heat exchange

five advantages

- 1) High heat exchange efficiency (using high-efficiency finned heat exchange tubes and spiral coil tube structure);
- 2) Small size, saving installation space;
- 3) Excellent water quality (water pipes are made of pure copper);
- 4) Strong frost resistance (large cross-sectional area of water circulation, not easy to block and freeze crack);
- 5) Stable and reliable (no solder joints in the internal copper pipe, no risk of solder leakage);



Modular Fixed Frequency Air-cooled Scroll Chiller

Specifications

Specifications - Total Heat Recovery Type (TCA-XHR)
380V-3N-50Hz

Model		TCA201XHR/1	
Power supply		V-ph-Hz	380-3-50
Cooling	Cooling capacity	kW	66
	Cooling power input	kW	20
	Cooling current	A	40.3
Heating	Heating capacity	kW	70
	Heating power input	kW	21
	Heating current	A	41.4
Maximum power input		kW	30.2
Maximum input current		A	50
Starting current		A	140
Energy regulation		%	0-100
Compressor	Type	-	Hermetic scroll compressor
	Brand	-	Emerson
	Qty	-	1
Evaporator	Type	-	High-efficiency shell-and-tube heat exchang
	Water flo	m ³ /h	11.4
	Water pressure drop	kPa	18
	Connection pipe dimension	-	DN65 flange connectio
Fan	Qty	-	2
	Air flo	m ³ /h	26000
	Current	A	2.35
	Power	kW	1.13
Unit dimensions (L*W*H)		mm	2200x860x1980
Packaging dimensions (L*W*H)		mm	2260x920x1980
Net weight		kg	650/710
Operating weight		kg	650/710
Refrigerant	Type	-	R410A
Domestic hot water mode	Rated water flo	m ³ /h	13.1
	Nominal heating capacity	kW	76
	Heating power input	kW	18.4
	Current	A	40.6
	Nominal water output	m ³ /h	1.63
Cooling+heat recovery mode	Nominal cooling capacity	kW	60
	Nominal heat recovery capacity	kW	76
	Nominal input power	kW	16.5
	Current	A	35.6
	Nominal water output	m ³ /h	1.63
	Water flow at air conditioner sid	m ³ /h	10.3
	Water flow at hot water sid	m ³ /h	13.1

★ Note:

- Cooling mode: Nominal cooling operating conditions: water flow volume 11.4m³/h, chilled water outlet temperature 7°C, ambient temperature 35°C
Nominal heating operating conditions: water flow 1.4m³/h, hot water outlet temperature 45°C, ambient dry/wet bulb temperature 7°C/6°C.
- Heating water mode: Nominal conditions: water flow volume 13.1 m³/h, hot water outlet temperature 45°C, ambient dry/wet bulb temperature 20/15°C.
- Cooling + heat recovery mode: Cooling mode cooling water flow volume 10.3m³/h, LWT 7°C, heat recovery mode: hot water water flow volume 13.1m³/h, hot water outlet temperature 45°C
- Nominal heating operating conditions: initial water temperature 15°C, cadence water temperature 55eC, ambient dry/wet bulb temperature 20/15°C.
- In actual use, the cooling/heating loss should be considered after the installation of the system piping, pumps, valve, dirt, etc. about 6%.
- The units can be combined freely. Each system can combine up to 16 modules.
- There will be no further notice if the parameters changes due to product optimization.
- The controllers need to be ordered separately, including wired controller, communication line, IOM, temperature sensor. Manufacturer reserves the right to make changes to above specifications without prior notice, please refer to the factory configuration when purchasin

4-Pipe Modular Chiller(TCA-XHF)

The 4-pipe modular air-cooled chiller (heat pump) adopts R410A eco-friendly refrigerant, and supports cooling, heating, and cooling heat recovery operations. It is widely applied in places with higher requirements for temperature and humidity, such as hospitals, art galleries, and equipment rooms. When cold water is used for dehumidification, re-heating is obtained free of charge. The unit can also be applied in building complexes which require both cooling and heating, to greatly save operating cost and initial investment in equipment. Without the need for a dedicated equipment room and cooling tower, the 4-pipe modular air-cooled chiller (heat pump) unit is the best choice in prosperous areas and the water shortage areas.



Maximized Energy Utilization

In places where both cooling and heating are required and specific temperature and humidity limits are set, separate configuration for cooling and heating is not required. The waste heat emitted during cooling can be recovered for producing hot water, which will be used by air side products. The ICOP can reach up to 7.78, substantially reducing initial investment and later-phase operating costs.



Auto Balance of Cooling and Heating

With a modular design and self-adapting cooling and heat balancing technologies, the unit can automatically adjust the output of cooling and heating capacity based on actual conditions, and fast switch the operating status and control the water outlet temperature to achieve continuous balancing that enables "output on demand". Both temperature and humidity are controlled more accurately to provide enhanced comfort.



Wide Operation Range

The unit adopts well-known multi-speed fans to further reduce operation noise and implement smart air flow adjustment, so as to support stable cooling and heating within a wide range of -15°C to +48°C.

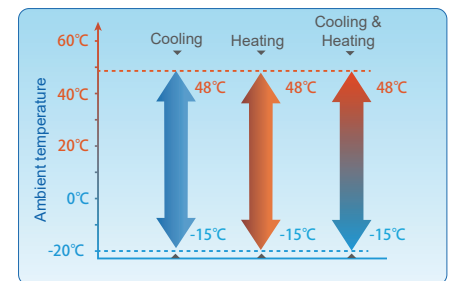

Operating range of units

Modular Fixed Frequency Air-cooled Scroll Chiller

Performance Parameters (4-Pipe Units)

Model			TCA201XHF	
Cooling only	Nominal cooling capacity		kW	66
	Rated input power for cooling		kW	20
	Water flo		m ³ /h	11.4
	COP		-	3.3
Heating only	Nominal heating capacity		kW	70
	Rated input power for heating		kW	20
	Water flo		m ³ /h	13.9
Cooling and heating	Nominal cooling capacity		kW	63
	Nominal heating capacity		kW	81
	Total nominal power		kW	18.5
	Rated water flo	Cold water side	m ³ /h	11.4
		Hot water side	m ³ /h	13.9
Power supply			-	380 V 3N ~ 50 Hz
Water resistance	Cold water side		kPa	40
	Hot water side		kPa	60
Water inlet/outlet pipe diameter	Cold water side		-	DN65 (flange connection)
	Hot water side		-	DN65 (internal thread)
Fan	Type		-	Low-noise axial fan
	Qty	Set		2
	Air flo		m ³ /h	26000
Compressor	Type		-	Hermetic scroll compressor
	Qty	Set		1
Operating mode			-	Automatic operation controlled by microcomputers
Refrigerant	Type		-	R410A
Unit weight			kg	650
Operating weight			kg	710
Dimensions	Length		mm	2200
	Width		mm	860
	Height		mm	1980

Capacity Parameters of Combined Units

Model and Quantity		TCA201XHF	1	2	3	4	5	6	7	8	9	10	11	12	13	14	15	16
Cooling only	Cooling capacity	kW	66	132	198	264	330	396	462	528	594	660	726	792	858	924	990	1056
	Water flo at cold water side	m ³ /h	11.4	22.8	34.2	45.6	57	68.4	79.8	91.2	102.6	114	125.4	136.8	148.2	159.6	171	182.4
Heating only	Heating capacity	kW	70	140	210	280	350	420	490	560	630	700	770	840	910	980	1050	1120
	Water flow at hot water side	m ³ /h	13.9	27.8	41.7	55.6	69.5	83.4	97.3	111.2	125.1	139	152.9	166.8	180.7	194.6	208.5	222.4
Cooling and heating	Cooling capacity	kW	63	126	189	252	315	378	441	504	567	630	693	756	819	882	945	1008
	Heating capacity	kW	81	162	243	324	405	486	567	648	729	810	891	972	1053	1134	1215	1296

★ Remarks:

- The nominal cooling capacity is tested under the following conditions: water flow of 11.4 m³/h; water outlet temperature of 7°C; outdoor environment DB temperature of 35°C.
The nominal heating capacity is tested under the following conditions: water flow of 13.9 m³/h; water outlet temperature of 45°C; outdoor environment DB/WB temperature of 7°C/6°C.
- The nominal cooling+heating capacity is tested under the following conditions: water flow at cold water side of 11.4 m³/h; water outlet temperature of 7°C; water flow at hot water side of 13.9 m³/h; water outlet temperature of 45°C.
- The operation range in cooling mode, heating mode, and cooling+heating mode is -15°C to +48°C.
- About 6% loss caused by system pipelines, water pumps, valves, and dirt after unit installation shall be considered for the cooling (heating) capacity in actual applications.
- Parameters listed in the above tables are for a single module. Up to 16 modules can be used together.
- The specifications are subject to change due to product improvement without prior notice
- The control accessory box needs to be purchased separately, which contains the wired controller, wired controller communication cable, user manual, temperature sensor, etc. The box content may change. Please refer to the actual factory configurations

High-Heat Efficiency Modular Chiller(TCA-XH)

The unit is designed with TICA's experience in R&D of modular unit, featuring the most advanced EVI compressor from EMERSON and applicable for a wider range of heating.

Widely Operation Range Of Heating

The advanced EVI compressor technology is adopted for twostage compression, wider operation range of efficient heating at ambient temperature of $-25^{\circ}\text{C}\sim 25^{\circ}\text{C}$ to satisfy a wider range of requirements.

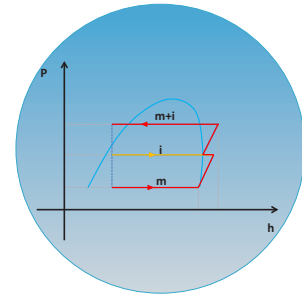

Precision Throttle Control Technology Of Electronic EXV

The electronic expansion valve achieves 480 regulating range, supplemented by TICA's patented precision throttle control technology to realize dynamic matching in refrigerating system, fully improve the optimum efficiency of each component and ensure the optimum condition of system operation pressure and temperature.

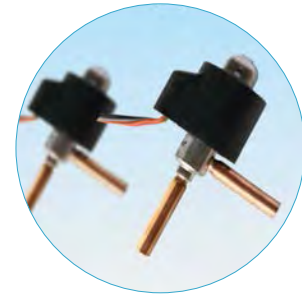

EVI Compressor

The high-heat efficiency modular unit employs the efficient EVI technology, with a secondary suction port fitted on the scroll plate. The refrigerant volume is increased through the secondary suction loop and the enthalpy difference of refrigerant in the major cycle is increased to improve the efficiency of cooling and heating.

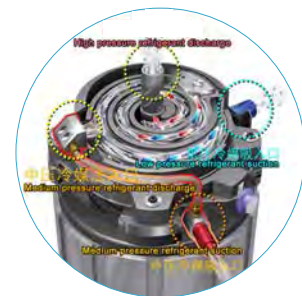

Low Carbon And Environmental Protection

The unit uses the environment-friendly refrigerant R410A, and combines air source heat pump and EVI technologies. It can be used in the northern area for cooling in summer and heat pump heating in winter, providing lower-carbon and more environment-friendly applications.



Modular Fixed Frequency Air-cooled Scroll Chiller

Specification(High-Heat Efficiency)

Specifications - High-heat Efficiency Type (TCA-XHE)
380V-3N-50Hz

Model			TCA201XHE	TCA401XHE
Power supply		V-ph-Hz	380-3-50	380-3-50
Cooling	Cooling capacity	kW	70	150
	Cooling power input	kW	20.4	43.8
	Cooling current	A	41.4	77.5
Heating	Heating capacity	kW	78	160
	Heating power input	kW	20.8	44
	Heating current	A	41.3	78.3
Maximum power input		kW	31	58
Maximum input current		A	60	105
Starting current		A	126.6	260.2
Energy regulation		%	0-50-100	0-50-100
Compressor	Type	-	Hermetic EVI scroll compressor	
	Brand	-	Emerson	Emerson
	Qty	-	2	2
Evaporator	Type	-	High-efficiency shell-and-tube heat exchange	
	Water flo	m ³ /h	12	25.8
	Water pressure drop	kPa	50	54
	Connection pipe dimension	-	DN65 flange connectio	DN80 flange connectio
Fan	Qty	-	2	4
	Air flo	m ³ /h	30000	60000
	Current	A	2.6	2.6
	Power	kW	0.9	0.9
Unit dimensions (L*W*H)		mm	2200x860x2190	2200x1720x2190
Packaging dimensions (L*W*H)		mm	2260x920x2190	2260x1780x2190
Net weight		kg	665	1150
Operating weight		kg	710	1250
Refrigerant	Type	-	R410A	R410A

★ Notes:

1. Nominal cooling operating conditions: leaving water temperature 7°C, ambient temperature 35°C; Nominal heating operating conditions: leaving water temperature 45°C, outdoor dry bulb temperature 7°C, wet bulb temperature 6°C;
2. In actual use, the cooling/heating loss should be considered after the installation of the system piping, pumps, valve, dirt, etc. about 6%;
3. For other working conditions or capacity parameters, Please contact TICA offices for cooling ambient condition under 5°C;
4. There will be no further notice if the parameters changes due to product optimization.
5. The units can be combined freely. Each system can combine up to 12 modules.
6. The controllers need to be ordered separately, including wired controller, communication line, IOM, temperature sensor. Manufacturer reserves the right to make changes to above specifications without prior notice, please refer to the factory configuration when purchasing.

Year-round Cooling modular Chiller(TCA-XHA)

TICA's new generation of year-round cooling modular unit is applicable for industrial applications, and requirements on energy saving and environment protection. It can operate for refrigeration at the ambient temperature of $-10^{\circ}\text{C} \sim 48^{\circ}\text{C}$ all the year round, with environment-friendly refrigerant R410A, advanced electronic expansion valve control technology, efficient shell and tube heat exchanger, EC fan with stepless speed regulation, fully meeting the requirements of various industry applications for chilled water throughout the year.

Widely Operation Range Of Cooling

The modular water chiller unit is specially designed and can run in all weathers at the ambient temperature of $-10^{\circ}\text{C} \sim 48^{\circ}\text{C}$.



DC Fan With Stepless Speed Regulation

The condensate fan employs the DC brushless motor of which the speed is variable between 20%-100% to ensure that condensing pressure is within the range of safe operation under all conditions for longer service life.



High Precision Electronic Expansion Valve

The electronic expansion valve achieves 480 regulating range, supplemented by TICA's patented precision throttle control technology to realize dynamic matching in refrigerating system, fully improve the optimum efficiency of each component and ensure the optimum condition of system operation pressure and temperature.

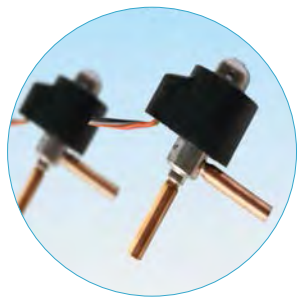

Dry-type Shell And Tube Heat Exchanger

The unit employs efficient dry-type heat exchanger as the waterside heat exchanger which has excellent anti-freezing performance and higher tolerance to impurities in water system, ensuring more reliable and stable operation of the unit.





Modular Fixed Frequency Air-cooled Scroll Chiller

Specification(Year-round Cooling)

Specifications - Year-round Cooling Type (TCA-XHA)
380V-3N-50Hz

Model			TCA201XHA
Power supply		V-ph-Hz	380-3-50
Cooling	Cooling capacity	kW	66
	Cooling power input	kW	20
	Cooling current	A	40.3
Heating	Heating capacity	kW	70
	Heating power input	kW	21
	Heating current	A	41.4
Maximum power input		kW	30.2
Maximum input current		A	50
Starting current		A	140
Energy regulation		%	0-50-100
Compressor	Type	-	Hermetic scroll compressor
	Brand	-	Emerson
	Qty	-	2
Evaporator	Type	-	High-efficiency shell-and-tube heat exchang
	Water flo	m ³ /h	11.4
	Water pressure drop	kPa	45
	Connection pipe dimension	-	DN65 flange connectio
Fan	Qty	-	2
	Air flo	m ³ /h	26000
	Current	A	2.6/1.2
	Power	kW	0.9/0.25
Unit dimensions (L*W*H)		mm	2200×860×1980
Packaging dimensions (L*W*H)		mm	2260×920×1980
Net weight		kg	620
Operating weight		kg	680
Refrigerant	Type	-	R410A

ID	Item	standard	optional
1	Auxiliary electric heating	NO	Optional electric heating: 12kw, 15kw, 18kw, 20kw, 27kw, 32kw, 40kw, 45kw, 50kw, 54kw, 63kw, 72kw
2	Wiring controller		
3	Wiring controller wire length	30m	60m or 120m
4	External sheet metal	NO	YES
5	Heat Exchanger anticorrosion	NO	YES

★ Notes:

- Nominal cooling operating conditions: leaving water temperature 7°C, ambient temperature 35°C;
- In actual use, the cooling/heating loss should be considered after the installation of the system piping, pumps, valve, dirt, etc. about 6%;
- For other working conditions or capacity parameters, Please contact TICA ;
- There will be no further notice if the parameters changes due to product optimization.
- The units can be combined freely. Each system can combine up to 12 modules.
- The controllers need to be ordered separately, including wired controller, communication line, IOM, temperature sensor. Manufacturer reserves the right to make changes to above specifications without prior notice, please refer to the factory configuration when purchasing.

Capacity Correction Factor

Cooling Correction Coefficient Table

Leaving Water Temperature °C	Ambient Temperature (°C)																	
	5		10		15		20		25		30		35		40		48	
	Cooling	Power input	Cooling	Power input	Cooling	Power input	Cooling	Power input	Cooling	Power input	Cooling	Power input	Cooling	Power input	Cooling	Power input	Cooling	Power input
5	1.06	0.72	1.08	0.73	1.09	0.71	1.09	0.78	1.04	0.84	0.99	0.90	0.93	0.97	0.87	1.01	0.80	1.08
7	1.14	0.75	1.16	0.76	1.17	0.74	1.16	0.81	1.11	0.87	1.06	0.93	1.00	1.00	0.94	1.04	0.87	1.11
9	1.21	0.78	1.23	0.79	1.24	0.77	1.23	0.84	1.18	0.90	1.13	0.96	1.07	1.03	1.01	1.07	0.94	1.14
12	1.28	0.81	1.30	0.82	1.31	0.80	1.30	0.87	1.25	0.93	1.20	0.99	1.14	1.06	1.08	1.10	1.01	1.17
15	1.35	0.84	1.37	0.85	1.38	0.83	1.37	0.90	1.32	0.96	1.27	1.02	1.21	1.09	1.15	1.13	1.08	1.20
20	1.40	0.88	1.43	0.89	1.44	0.87	1.42	0.94	1.38	1.00	1.32	1.06	1.26	1.13	1.20	1.17	1.13	1.24

★ Note: The above correction factors adapt to TCA201/301/401XH/G/S, TCA201/401XC, TCA201/401XE, TCA201XHR, TCA301XC/B, TCA401XC/A, TCA201XHF.

Heating Correction Coefficient Table

Leaving Water Temperature °C	Ambient Temperature (°C)																	
	-15		-10		-5		0		7		10		15		20		25	
	Heating	Power input	Heating	Power input	Heating	Power input	Heating	Power input	Heating	Power input	Heating	Power input	Heating	Power input	Heating	Power input	Heating	Power input
30	0.50	0.71	0.65	0.72	0.76	0.73	0.89	0.79	1.05	0.83	1.12	0.85	1.20	0.87	1.30	0.89	1.37	0.91
35	0.48	0.77	0.63	0.78	0.74	0.79	0.87	0.85	1.03	0.89	1.10	0.91	1.18	0.93	1.28	0.95	1.35	0.97
40	0.46	0.83	0.61	0.84	0.72	0.85	0.85	0.91	1.01	0.95	1.06	0.97	1.14	0.99	1.24	1.01	1.31	1.03
45	-	-	0.60	0.89	0.71	0.90	0.84	0.96	1.00	1.00	1.03	1.03	1.11	1.05	1.21	1.07	1.28	1.09
50	-	-	-	-	0.68	0.96	0.81	1.02	0.97	1.06	1.00	1.09	1.08	1.11	1.18	1.13	1.25	1.15

★ Note: The above correction factors adapt to TCA201/301/401XH/G/S, TCA201XHR, TCA201XHA, TCA201XHF (excluding the data under the ambient temperature of -15°C).

Cooling Capacity Correction Table of Strong-cold/High-heat efficiency Modular Un

Leaving Water Temperature °C	Ambient Temperature (°C)																	
	5		10		15		20		25		30		35		40		48	
	Cooling	Power input	Cooling	Power input	Cooling	Power input	Cooling	Power input	Cooling	Power input	Cooling	Power input	Cooling	Power input	Cooling	Power input	Cooling	Power input
5	1.07	0.71	1.09	0.72	1.10	0.70	1.10	0.77	1.05	0.83	1.00	0.89	0.93	0.97	0.87	1.00	0.80	1.07
7	1.15	0.74	1.17	0.75	1.18	0.73	1.17	0.80	1.12	0.86	1.07	0.92	1.00	1.00	0.94	1.03	0.87	1.10
9	1.22	0.77	1.24	0.78	1.25	0.76	1.24	0.83	1.19	0.89	1.14	0.95	1.07	1.03	1.01	1.06	0.94	1.13
12	1.30	0.80	1.32	0.81	1.33	0.79	1.32	0.86	1.27	0.92	1.22	0.98	1.14	1.06	1.08	1.09	1.01	1.16
15	1.37	0.83	1.39	0.84	1.40	0.82	1.39	0.89	1.34	0.95	1.29	1.01	1.21	1.09	1.15	1.12	1.08	1.19
20	1.42	0.86	1.45	0.87	1.46	0.85	1.44	0.92	1.40	0.98	1.34	1.04	1.26	1.13	1.20	1.15	1.13	1.22

★ Note: The above correction factors adapt to TCA201/401XE.

Modular Fixed Frequency Air-cooled Scroll Chiller

Heating Capacity Correction Table of Strong-cold/High-heat efficient

Leaving Water Temperature °C	Ambient Temperature (°C)																					
	-25		-20		-15		-10		-5		0		7		10		15		20		25	
	Heating	Power input	Heating	Power input	Heating	Power input	Heating	Power input	Heating	Power input	Heating	Power input	Heating	Power input	Heating	Power input	Heating	Power input	Heating	Power input	Heating	Power input
30	0.47	0.76	0.55	0.77	0.62	0.77	0.71	0.77	0.77	0.77	0.81	0.76	0.99	0.77	1.16	0.79	1.21	0.86	1.23	0.89	1.24	0.88
35	0.47	0.81	0.54	0.81	0.61	0.81	0.70	0.82	0.76	0.82	0.80	0.82	0.98	0.83	1.13	0.86	1.18	0.90	1.20	0.93	1.20	0.92
40	0.46	0.88	0.55	0.88	0.61	0.88	0.71	0.88	0.77	0.88	0.82	0.89	0.99	0.90	1.09	0.93	1.15	0.97	1.18	1.00	1.18	1.00
45	0.46	0.99	0.56	0.98	0.61	0.99	0.71	0.99	0.77	0.99	0.85	0.99	1.00	1.00	1.08	1.04	1.14	1.08	1.17	1.12	1.17	1.12
50	-	-	0.56	1.10	0.61	1.11	0.71	1.11	0.78	1.11	0.84	1.12	0.99	1.13	1.07	1.13	1.13	1.15	1.16	1.16	1.15	1.15
55	-	-	-	-	-	-	-	-	-	-	0.83	1.22	0.97	1.23	1.08	1.23	1.11	1.25	1.15	1.26	1.14	1.25

★ Note: The above correction factors adapt to TCA201/401XHE.

Heating+Heat Recovery Capacity Correction Table

Leaving Water Temperature at Heat Recovery Side °C	Leaving Water Temperature of the Air Conditioner °C											
	7			8			9			10		
	Cooling capacity	Heat recovery capacity	Power input	Cooling capacity	Heat recovery capacity	Power input	Cooling capacity	Heat recovery capacity	Power input	Cooling capacity	Heat recovery capacity	Power input
35	1.14	1.03	0.83	1.16	1.05	0.83	1.19	1.08	0.84	1.23	1.11	0.85
40	1.11	1.03	0.95	1.14	1.04	0.95	1.18	1.07	0.95	1.20	1.11	0.95
45	1.00	1.00	1.00	1.05	1.03	1.02	1.11	1.07	1.04	1.17	1.10	1.06
50	0.99	0.99	1.15	1.03	1.02	1.15	1.07	1.05	1.16	1.12	1.09	1.17
55	0.97	0.99	1.25	1.02	1.01	1.26	1.04	1.04	1.26	1.08	1.07	1.27

★ Note: The above correction factors adapt to TCA201XHR.

Water Heating Capacity Correction Table

Leaving Water Temperature at Heat Recovery Side °C	Ambient Temperature (°C)											
	-10		-5		0		5		10		15	
	Heating Capacity	Power input	Heating Capacity	Power input	Heating Capacity	Power input	Heating Capacity	Power input	Heating Capacity	Power input	Heating Capacity	Power input
35	0.58	0.81	0.68	0.82	0.80	0.83	0.95	0.85	1.01	0.86	1.09	0.88
40	0.56	0.86	0.66	0.88	0.78	0.89	0.93	0.90	0.98	0.91	1.05	0.92
45	-	-	0.63	0.94	0.77	0.95	0.92	0.97	0.95	0.98	0.97	0.99
50	-	-	-	-	0.74	1.06	0.90	1.09	0.93	1.10	0.95	1.10
55	-	-	-	-	-	-	0.86	1.18	0.89	1.20	0.92	1.20

★ Note: The above correction factors adapt to TCA201XHR.

Cooling Capacity Correction Table of All Conditions

Leaving Water Temperature °C	Ambient Temperature (°C)																											
	-20		-15		-10		-5		0		5		10		15		20		25		30		35		40		48	
	Cooling	Power input	Cooling	Power input	Cooling	Power input	Cooling	Power input	Cooling	Power input	Cooling	Power input	Cooling	Power input	Cooling	Power input	Cooling	Power input	Cooling	Power input	Cooling	Power input	Cooling	Power input	Cooling	Power input	Cooling	Power input
5	1.15	0.43	1.12	0.49	1.09	0.57	1.06	0.63	1.09	0.66	1.06	0.72	1.08	0.73	1.09	0.71	1.09	0.78	1.04	0.84	0.99	0.90	0.93	0.97	0.87	1.01	0.80	1.08
7	1.20	0.44	1.18	0.50	1.16	0.58	1.14	0.66	1.17	0.69	1.14	0.75	1.16	0.76	1.17	0.74	1.16	0.81	1.11	0.87	1.06	0.93	1.00	1.00	0.94	1.04	0.87	1.11
9	1.24	0.45	1.23	0.51	1.22	0.59	1.21	0.69	1.24	0.72	1.21	0.78	1.23	0.79	1.24	0.77	1.23	0.84	1.18	0.90	1.13	0.96	1.07	1.03	1.01	1.07	0.94	1.14
12	1.27	0.46	1.27	0.52	1.27	0.60	1.28	0.72	1.31	0.75	1.28	0.81	1.30	0.82	1.31	0.80	1.30	0.87	1.25	0.93	1.20	0.99	1.14	1.06	1.08	1.10	1.01	1.17
15	1.32	0.47	1.33	0.53	1.33	0.60	1.35	0.75	1.38	0.78	1.35	0.84	1.37	0.85	1.38	0.83	1.37	0.90	1.32	0.96	1.27	1.02	1.21	1.09	1.15	1.13	1.08	1.20
20	1.34	0.49	1.35	0.55	1.35	0.62	1.39	0.78	1.43	0.81	1.38	0.86	1.41	0.88	1.43	0.85	1.42	0.92	1.37	0.99	1.34	1.04	1.27	1.12	1.21	1.15	1.14	1.23

★ Note: The above correction factors adapt to TCA201XHA.

Unit Dimension (mm)

TCA201XHA

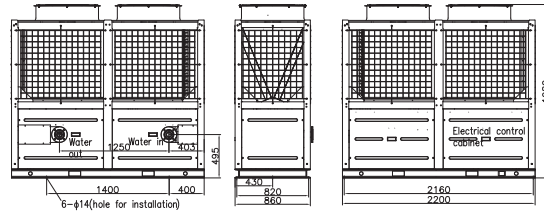

TCA201XH. TCA201XC

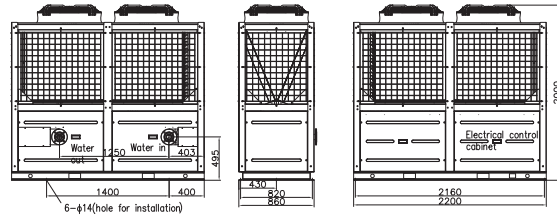

TCA301XH. TCA401XH. TCA401XC. TCA301XC/B. TCA401XC/A

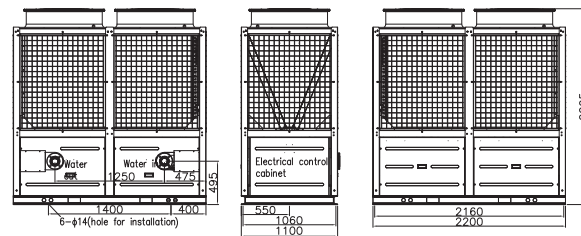

TCA201XHE

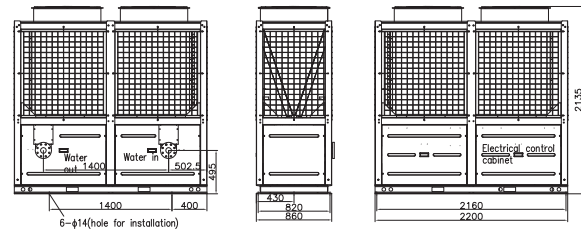

TCA401XHE

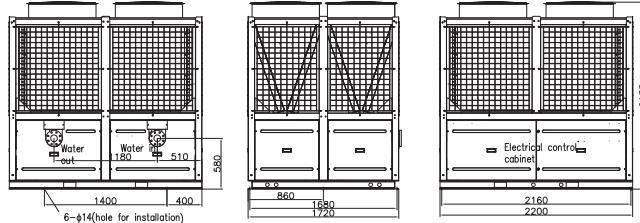

TCA201XHR/1. TCA201XHF

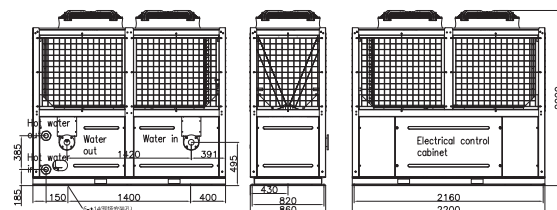

Large Air-cooled Scroll Chiller

CE



Model Nomenclature

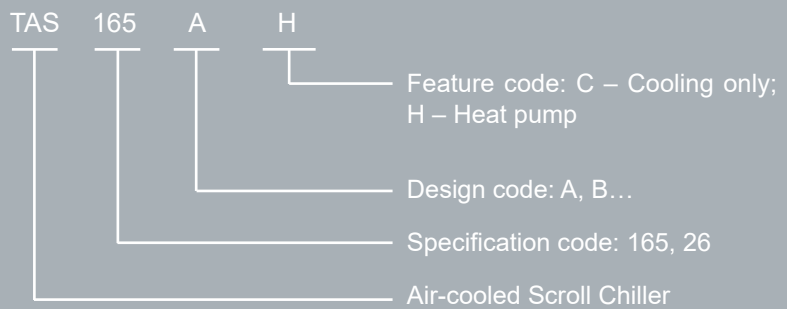

Features

Environmental friendly

TICA air cooled scroll chiller (heat pump) uses eco-friendly refrigerant R410A. Such chlorine-free refrigerant does not harm the ozone layer (zero-ODP), and is stable and non-toxic. Therefore, it is environmental friendly and is unlikely to be replaced. In addition, it is good in heat exchanging, which could help boost the unit performance and lower energy consumption.



High-end configuratio

Efficient flexible scroll compres

The unit uses the well-known hermetic efficient scroll compressor and the optimized scroll and sealing ring so that the refrigerant compressor features axial and radial flexibility. This not only effectively reduces refrigerant leakage, but also raises the volumetric efficiency of the compressor. Moreover, each compressor is equipped with a unidirectional discharge valve to avoid backflow of the refrigerant and ensure that the compressor can run stably in the full operating condition.

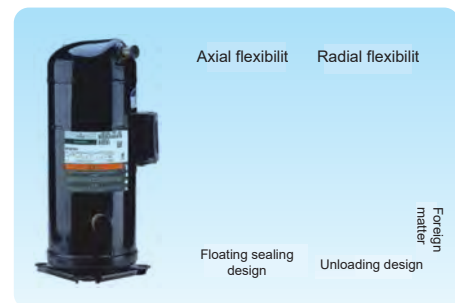

High-precision electronic expansion valve

The unit adopts the 480-step electronic expansion valve of premium brand (for total heat recovery: 500 steps) for precise adjustment of refrigerant flow. And with TICA's patented control technology, refrigerant in the system is dynamically adjusted to suit the load demands in a fast and accurate way, to greatly improve the unit energy efficiency. (Patent No.: ZL 2013 2 0345187.X)

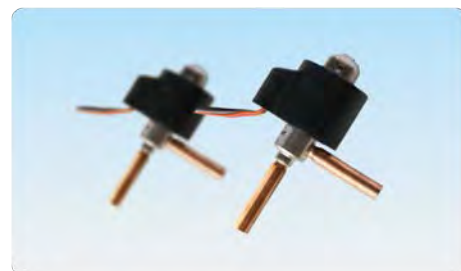

Efficient water-side shell-and-tube heat exchanger

The water-side heat exchanger employs the efficient shell-and-tube heat exchanger. Compared with the plate heat exchanger, the shell-and-tube heat exchanger provides wider water-side channels and produces less water resistance and scale, with less possibility of being blocked by impurity. Therefore, the shell-and-tube heat exchanger raises lower requirements for water quality and is equipped with more powerful anti-freezing capability.

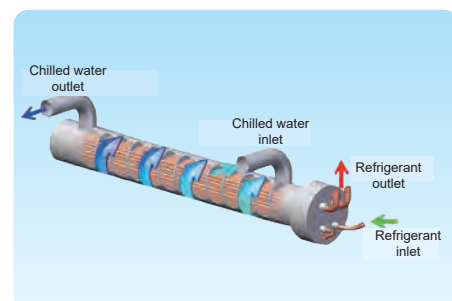

The unit uses the well-known hermetic efficient scroll compressor and the optimized scroll and sealing ring so that the refrigerant compressor features axial and radial flexibility. This not only effectively reduces refrigerant leakage, but also raises the volumetric efficiency of the compressor. Moreover, each compressor is equipped with a unidirectional discharge valve to avoid backflow of the refrigerant and ensure that the compressor can run stably in the full operating condition.

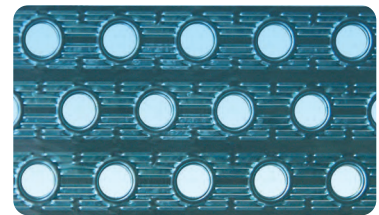

High-performance fan

The air cooled scroll chiller (heat pump) is installed with IP54-rated (or higher) fan motor, to ensure safe and reliable running in the most severe weather conditions..



Professional design

Unique energy regulation

When TICA air cooled scroll chiller (heat pump) is deployed in a modular system, the energy control part employs TICA's patented smart energy regulation technology, and based on which, the first system of each modular unit is loaded before loading the corresponding second system. In this way, the inlet and outlet water temperature difference of the modular unit at part load can be effectively balanced with less water temperature fluctuation, to raise the energy efficiency ratio of the modular unit at part load and enhance the anti-freezing capability of the water-side heat exchanger in winter, making the multi-modular unit a compact and easy-to-use system that features high efficiency and automatic energy regulation (Patent No.: ZL 2013 2 0344732.3)

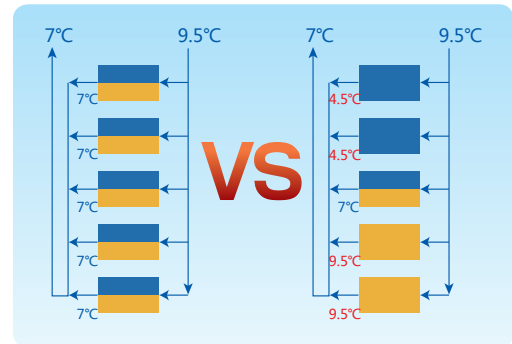

Smart air flow regulation

With the common air system, the new-generation air cooled scroll chiller (heat pump) implements hierarchical control of fans. The unit with a single module can automatically adjust the number of active fans based on the ambient temperature so that the air flow change of the unit best matches the load change without frequently powering on or off fans. Therefore, the pressure of the system is stable with small water temperature fluctuation and the modular unit can run more reliably. Moreover, the common air system and hierarchical fan control design greatly increases the temperature ranges of the unit in cooling and heating modes.



High efficiency & energy saving

According to the national authoritative detection institute, the EER of TICA air cooled scroll chiller (heat pump) at full load is greater than 3.3, reaching and exceeding national grade 2 energy efficiency standard. TICA air cooled scroll chiller (heat pump) has achieved the Energy Conservation Certification issued by the authoritative detection institute certified by China National Accreditation Service for Conformity Assessment (CNAS), and has been included into the energy-saving product procurement list of China.

The whole unit adopts air-cooled mode without the need of large external equipment such as boiler and cooling tower, thereby reducing initial investment and OPEX of users. TICA air cooled chiller (heat pump) efficiently saves energy, having safe and eco-friendly characteristics.



Reliable running

Three guarantee

With three patented technologies resolving specific problems, the defrosting feature of air cooled scroll chiller (heat pump) is further improved to guarantee efficient defrosting in winter and excellent heating capacity of the unit

First guarantee

With the patented defrosting technology, the system determines the defrosting conditions according to the ambient temperature, evaporation temperature, and running time in heating mode. Meanwhile, the patented defrosting technology ensures that the unit can be efficiently defrosted when there is frost, and stably supply heat when there is no frost. The running efficiency of the unit in heating mode is more than 90%. The EER in heating mode significantly increases

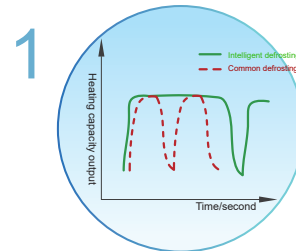

Second guarantee

The patented unidirectional valve technology refers to deploying a unidirectional valve at the last refrigerant loop at the bottom of the heat exchanger to prevent the refrigerant at low temperature in heating mode from entering the last loop at the bottom, without blocking the flow of the refrigerant at high temperature during defrosting. This technology not only prevents frost, but also greatly reduces the risk of being frosted and frozen at the bottom.



Third guarantee

The suspended bottom design refers to reserving space between the bottom of the fin heat exchanger and the horizontal plate sheet without affecting water flow after defrosting. Therefore, water can more easily drain and the possibility of water accumulation and freezing is reduced.



Improved protection functions

The unit programs have multiple protection functions to guarantee stable and reliable running. TICA air cooled scroll chiller (heat pump) is equipped with a water flow switch, which does not need to be installed and debugged during installation. This makes the unit running safer, simplifies the installation process, and reduces the costs, thus providing a cost-effective and convenient solution to customers

Communication failure protection	Sensor fault protection
Protection of too high air discharge temperature	Frequent startup protection
Compressor high-current protection	Balancing wear during hardware usage
Compressor low-current protection	High pressure protection
Protection of too low outlet water temperature	Low voltage protection
Protection of too high outlet water temperature	Fan overload protection
Phase sequence protection	Protection against insufficient water flow
Automatic anti-freezing protection	External interlocking protection



Intelligent control

Microcomputer control system

Air cooled scroll chiller (heat pump) employs the third-generation microcomputer control system and wired controllers that are upgraded. The third-generation microcomputer control panel integrates phase sequence detection and current detection features and provides more USB ports to facilitate subsequent maintenance and upgrade of TICA self-developed control program.

Moreover, the unit supports modular control, and up to 8 modules can be combined in parallel mode. When the unit is deployed in a modular system, the master and slave units can be set on demand. A faulty master unit can be easily replaced without affecting monitoring and running of the entire system.

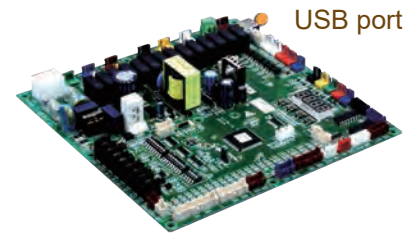

USB port

Diversified control function

Circulating water pump interlocking + Auxiliary electric heater interlocking + Fan coil interlocking

The control panel of the unit reserves the water pump interlocking control interface, auxiliary electric heater interlocking control interface, and the external interlocking interface. The unit supports interlocking control of the master water pump to prevent the unit from being damaged due to asynchronous startup of the water pump and unit. In winter, when the unit runs in heating mode, the switch of the auxiliary electric heater is controlled based on the load demand and the unit running status. The unit supports interlocking control of fan coil, controls unit power-on/power-off and loading/unloading according to the usage of the air side devices, thus enabling automatic running.



Water pump

Auxiliary electric heater

FCU

Remote power-on/power-off/mode switchover + Remote centralized control + Building automatic control

The control panel of the unit reserves the remote wired control switch/mode switchover interlocking interface. By adjusting the DIP switch, enable remote power-on/power-off/mode switchover. The reserved remote communication interface of the unit helps enable remote monitoring of the unit running and switch control. The unit is equipped with an RS485 communication interface that supports Modbus protocol. The unit supports building automatic control (BAS) system to enable centralized control and smart management of multiple modules.



User-friendly control

The unit is equipped with a perfect control program, providing the following functions: balanced running of the compressor, standby operation, smart anti-freezing running, manual defrosting, automatic fault judgment, automatic fault handling, and automatic alarm display. Additionally, the control part can use a multi-functional centralized controller (with keys/7" touch screen). The centralized controller can be customized to provide multiple functions, such as scheduled power-on/power-off, running on weekends/in holidays, memory upon power-off and multi-level passwords.



Specification

Model			TAS165AH	TAS260AH	TAS330AH	TAS440AH
Capacity	Cooling	kW	165	260	330	440
	Heating	kW	180	280	360	475
Power Input	Cooling	kW	50	78	101.8	135.8
	Heating	kW	54	84	108.1	142.6
Running Current	Cooling	A	100.8	158.7	184.5	245.6
	Heating	A	102.67	165.11	196.11	266.4
Power supply		V/N/Hz	380-3-50			
Maximum Input Power		kW	73.2	123.4	137.2	192
Maximum Input Current		A	135	220	240	330
Starting Current		A	203	274	319	417
Energy Regulation		%	0-25-50-75-100			
Water Side Heat Exchanger	Type	-	High efficient shell Tube heat exchanger			
	Water flo	m ³ /h	28.4	44.8	56.8	75.7
	Pressure drop	kPa	45	45	40	52
	Inlet/Outlet DN	DN	80	100	125	125
	Connection method	-	Victaulic connection			
Compressor	Brand	-	Danfoss		Copeland	
	Type	-	Scroll			
	Quantity	-	4	4	4	4
Fan	Type	-	Axial fan			
	Air flo	m ³ /h	60000	112000	120000	172000
	Quantity	-	4	4	8	8
Refrigerant	Type	-	R410A			
Unit Dimensions (L*W*H)		mm	2200×1720×2000	2200×2400×2235	4440×2260×2460	4440×2260×2460
Packaging Dimensions (L*W*H)		mm	2260×1780×2000	2260×2460×2235	4440×2260×2460	4440×2260×2460
Net weight		kg	1460	2050	2930	3700
Running weight		kg	1590	2250	3380	4200
Sound Level		dB	72	75	74	74

★ Remarks:

- The nominal cooling capacity and nominal cooling input power are tested at the rated water flo , water outlet temperature of 7°C, and outdoor dry-bulb temperature of 35°C.
The nominal heating capacity is tested at the rated water flo , water outlet temperature of 45°C, outdoor dry-bulb temperature of 7°C or outdoor wet-bulb temperature of 6°C.
- About 6% loss caused by system pipelines, water pumps, valves, and dirt after unit installation shall be considered for the cooling (heating) capacity in actual application.
- The operating range is 5°C to 48°C for cooling and -15°C to 48°C for heating. If the unit needs to run in cooling mode at an ambient temperature lower than 5°C, please contact TICA factory.
- The specifications above are based on a single module. Multiple modules can be used in combination. A maximum of 8 modules can be combined.
- As a separate item, control accessory box contains a wired controller, a wired controller communication cable, user manual, and temperature sensor. The configuration is subject to changes, so please refer to actual unit upon deliver .

Specifications under variable Operating Condition

Cooling correction table

Water outlet temperature °C	Ambient temperature °C																	
	5		10		15		20		25		30		35		40		48	
	Cooling	Input power	Cooling	Input power	Cooling	Input power	Cooling	Input power	Cooling	Input power	Cooling	Input power	Cooling	Input power	Cooling	Input power	Cooling	Input power
5	1.06	0.72	1.08	0.73	1.09	0.71	1.09	0.78	1.04	0.84	0.99	0.90	0.93	0.97	0.87	1.01	0.80	1.08
7	1.14	0.75	1.16	0.76	1.17	0.74	1.16	0.81	1.11	0.87	1.06	0.93	1.00	1.00	0.94	1.04	0.87	1.11
9	1.21	0.78	1.23	0.79	1.24	0.77	1.23	0.84	1.18	0.90	1.13	0.96	1.07	1.03	1.01	1.07	0.94	1.14
12	1.28	0.81	1.30	0.82	1.31	0.80	1.30	0.87	1.25	0.93	1.20	0.99	1.14	1.06	1.08	1.10	1.01	1.17
15	1.35	0.84	1.37	0.85	1.38	0.83	1.37	0.90	1.32	0.96	1.27	1.02	1.21	1.09	1.15	1.13	1.08	1.20
20	1.40	0.88	1.43	0.89	1.44	0.87	1.42	0.94	1.38	1.00	1.32	1.06	1.26	1.13	1.20	1.17	1.13	1.24

Heating correction Table

Water outlet temperature °C	Ambient temperature °C																	
	-15		-10		-5		0		7		10		15		20		25	
	Heating	Input power	Heating	Input power	Heating	Input power	Heating	Input power	Heating	Input power	Heating	Input power	Heating	Input power	Heating	Input power	Heating	Input power
30	0.50	0.71	0.65	0.72	0.76	0.73	0.89	0.79	1.05	0.83	1.12	0.85	1.20	0.87	1.30	0.89	1.37	0.91
35	0.48	0.77	0.63	0.78	0.74	0.79	0.87	0.85	1.03	0.89	1.10	0.91	1.18	0.93	1.28	0.95	1.35	0.97
40	0.46	0.83	0.61	0.84	0.72	0.85	0.85	0.91	1.01	0.95	1.06	0.97	1.14	0.99	1.24	1.01	1.31	1.03
45	-	-	0.60	0.89	0.71	0.90	0.84	0.96	1.00	1.00	1.03	1.03	1.11	1.05	1.21	1.07	1.28	1.09
50	-	-	-	-	0.68	0.96	0.81	1.02	0.97	1.06	1.00	1.09	1.08	1.11	1.18	1.13	1.25	1.15

Operating range

Model			TAS165AH	TAS260AH	TAS330AH	TAS440AH
			Minimum/Maximum			
Cooling	Chilled water outlet temperature	°C	5/20			
	Ambient temperature	°C	5/48			
Heating	Hot water outlet temperature	°C	30/50			
	Ambient temperature	°C	-10/48			
Water flo		m ³ /h	28.4	44.8	56.8	75.7
Water pressure drop		kPa	45	45	40	52
Maximum pressure on water side		Mpa	1			

Unit Dimensions

TAS165AH

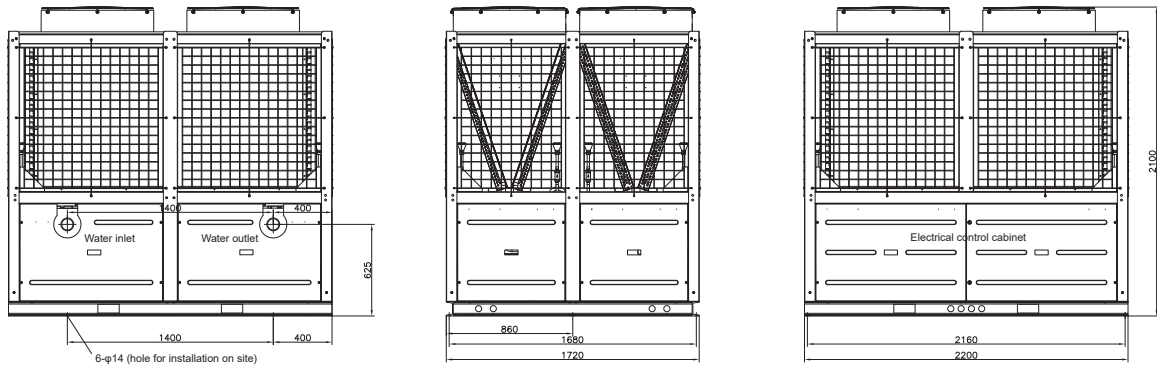

TAS260AH

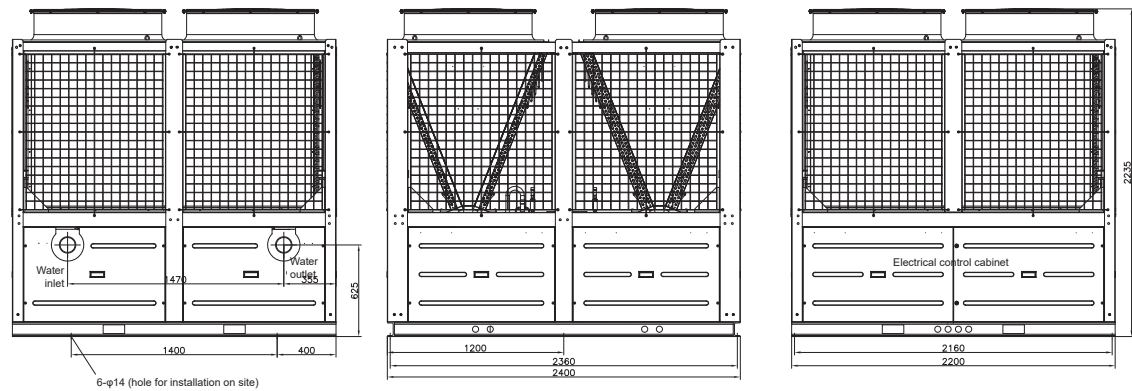

TAS430/330AH

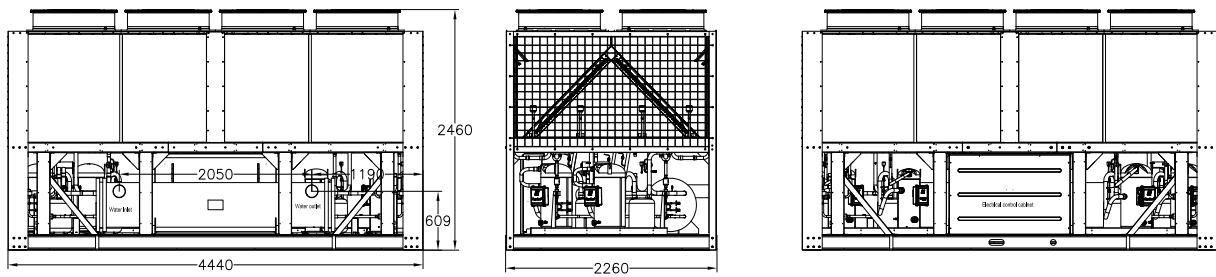

Water Scroll Chiller



Nomenclature

TWS 20 M D C 4

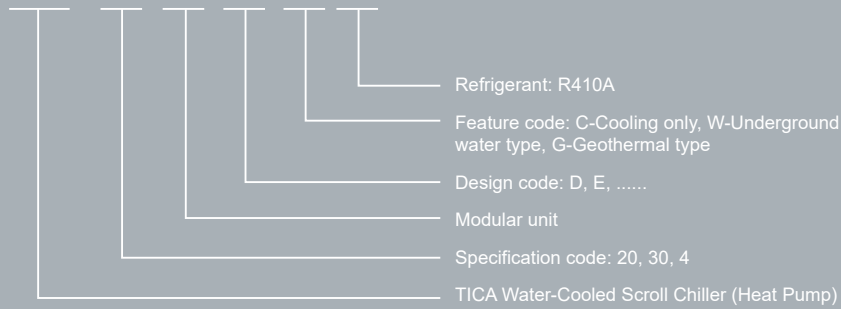

TICA environment-friendly water-cooled scroll-type TWS series specially recommended for small-to-mid-sized buildings

For customers, the product is featured by...



High efficiency & energy saving

- High EER, higher energy efficiency at partial load, saving the operation cost for the user.
- Due to modular operation, hierarchical startup saves energy



Healthy and comfortable

- The unit adopts the world-renowned hermetic scroll compressor, which runs quietly with low vibration.
- The unit can quickly and accurately meet the requirements of the user thanks to its superior control and powerful operation of the compressor.



Reliable and stable

- The modular design allows starting the units in a hierarchical way, reducing the impact of the startup current on the power grid.
- The unit is equipped with a variety of protection functions to ensure safe operation.
- The designed service life is long, protecting customer's investment.



Flexible and user-friendly

- Units can be purchased and installed by stages according to the actual need; thanks to the compact structure, the units do not need a special equipment room and can be installed on rooftop.
- The modular structure facilitates maintenance. Units are not affected when one unit is repaired or maintained.
- Units can be controlled in a centralized manner to facilitate routine management. The operation interface is user-friendly and meets various needs.

For designing institutes and installation, the product is featured by...

Environmental-friendly

- The unit adopts the environmental-friendly refrigerant HFC-410A, which is safe for the ozone layer and not subject to any restriction for use. It is highly appealing to designers advocating environmental protection.
- Outstanding cooling performance, low power consumption, low emission of CO2 emissions.



Easy unit selection

- The unit has three basic unit modules: 20RT, 30RT and 40RT, which can serve as an arbitrary combination of the master unit and the slave units. At most 12 units can be combined with a combined capacity of 20RT to 480RT at an interval of 10RT, facilitating the selection of units.

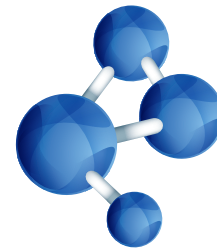

Easy handling

- The modules can be handled by elevator or forklift. No professional hoist is needed, thus saving the hoisting and labor costs.



Convenient Installation

- The unit can be transported separately, combined and installed conveniently and simply, thus shortening the installation period.

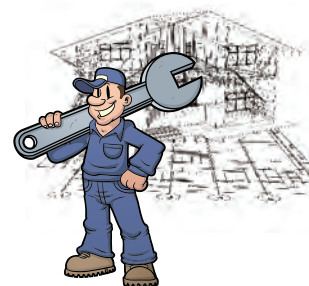

Performance Characteristics

High Efficiency & Energy Saving

■ Compressor

The units adopt the high-efficiency scroll compressors from a world-famous manufacturer. The compressor is featured by a small clearance capacity, small friction loss and high operation efficiency. Each modular unit is equipped with two scroll compressors. The combination of multiple modules provides multi-level capacity regulation, which is more energy efficient under operation with partial load.



■ Condenser and evaporator

It adopts the high-efficiency shell-and-tube heat exchanger with high-efficiency inner grooved copper tube, which improves the heat exchange efficiency; the heat exchange area is increased to lower the heat exchange temperature difference and improve the unit's COP; the condenser is equipped with a supercooling section at the bottom to effectively improve the supercooling of the refrigerant liquid; the modern manufacturing process and technologies ensure that the container is clean and free of impurities, thus improving the heat exchange efficiency; the heat exchanger undergoes strict flaw detection test and pressure inspection to ensure safety and reliability.

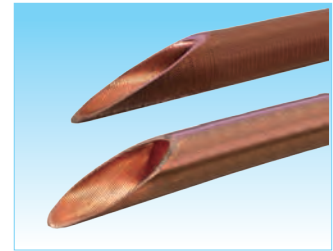

■ Cooling accessories

The expansion valve and protection control components all come from world-renown suppliers with reliable quality, ensuring that the unit can operate under high efficiency for a long time.

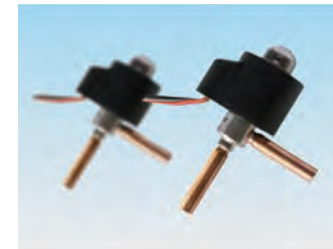

■ Low operation noise

The unit has outstanding configuration and optimized design. Components are carefully compared, selected and optimized; the structure and pipeline are optimized to lower the noise. The unit has undergone the noise test in a precision noise lab.

- Hermetic scroll compressor with small vibration from a world-famous supplier;
- Flexible installation base for the compressor, minimizing the vibration of the compressor;
- Optimized air suction and discharge pipelines, reducing the vibration of the unit.



■ The modular structure improves the power efficiency of the unit

Each module unit provides 2 energy regulation levels. Modules combined provide more energy regulation levels;
 The intelligent compressor operation balancing technology elevates the efficiency of the compressor with low load and saves energy for continuous operation;
 When one compressor fails, the failure has no impact on the other units;
 The modules can be combined in various ways and operate independently.

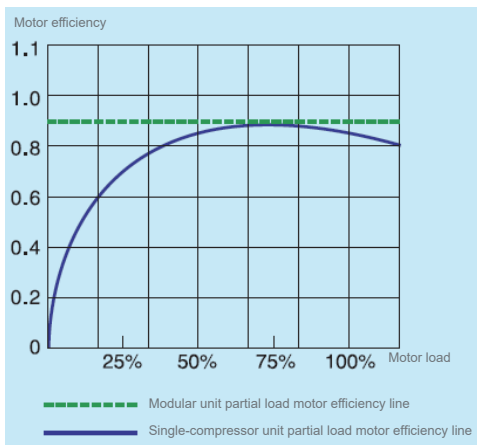

Recommended combination way

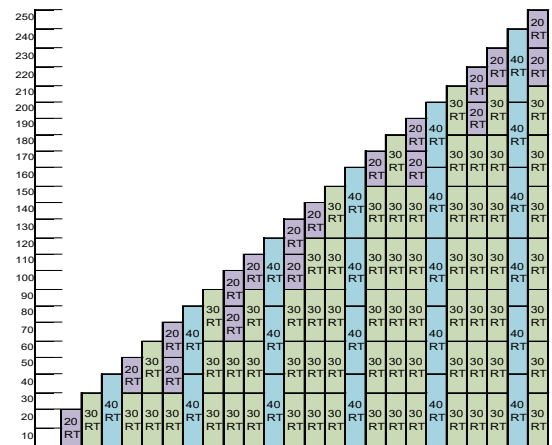

■ Multiple protection functions

The stability of air conditioner is very important for industrial and commercial users. TICA environmental-friendly water-cooled scroll chiller (heat pump) has been tested for a long time under conditions stricter than the national standard. The test result outperforms the national standard. The unit provides multiple protection technologies to ensure the normal operation, a long service life and safety of the unit.

- Phase sequence protection
- Frequent startup protection of the compressor
- Compressor overload protection
- Discharge temperature protection
- High and low pressure protection
- Disconnection protection
- Automatic freezing protection
- Automatic alarm and reset for some faults
- Automatic loading and unloading
- Powerful external interlocking



Intelligent Control

The unit is equipped with a user-friendly operation interface to meet various operational requirements of customers. The unit is equipped with microcomputer monitoring, which can realize various functions such as temperature control, time setting, memory, status display, alarm display, temperature setting and group control. The user can use its own control switch to control the unit and use external switches to realize remote control.



■ Alarm and protection functions

- 17 protection and fault protection functions
- Button lock
- Password protection parameter setting

■ Parameter setting functions

- Real-time settings
- Timed power-on/off setting
- Cooling water inlet/outlet temperature setting
- Heating water inlet/outlet temperature setting

■ Basic operation functions

- Cooling mode
- Heating mode

■ Other functions

- Historical failure check
- Remote control on/off
- The battery supports running of the real-time clock upon power-off

■ Intelligent control of signal output

- Cooling water pump control output
- Chilled water pump control output

■ Parameter display function

- Operating status check
- Compressor operation status display
- Chilled water temperature display
- Hot water temperature display
- Water pump operation status display
- Freezing protection display
- Communication indicator
- Displaying information under multi-color backlight
- Error code

Specification

Performance Specifications of Cooling-only Unit

Model TWS-MDC4	Cooling capacity kW	Power input kW	Compressor quantity	Number of energy regulation levels	Shell-and-tube evaporator				Shell-and-tube condenser			
					Water pipe diameter	Water flow m ³ /h	Water pressure drop kPa	Connection mode	Water pipe diameter	Water flow m ³ /h	Water pressure drop kPa	Connection mode
20	74.4	14.9	2	0-100%, 2 levels	DN50	12.8	39	Flexible clamp	DN65	16.0	24	Flexible clamp
30	112.2	22.4	2	0-100%, 2 levels	DN50	19.3	47		DN65	24.1	48	
40	146.3	29.2	2	0-100%, 2 levels	DN65	25.2	60		DN80	31.5	82	

Model TWS-MDC4	Compressor Type	Startup mode	Maximum running current A	Dimensions			Refrigeration system				Lubricant model	Weight	
				Length (mm)	Width (mm)	Height (mm)	Refrigerant	System quantity	Control mode	Charge amount kg		Shipping weight	Operating weight
20	Hermetic scroll compressor	Direct starting	48.0	1880	660	1380	R410A	2	EXV	12	RL32-3MAF	470	500
30			71.9	1880	660	1490		2		14.5		520	555
40			95.8	1880	740	1590		2		18		630	670

Notes:

- The above data is obtained based on nominal conditions of the unit: inlet/outlet chilled water temperature 12/7°C; inlet/outlet cooling water temperature 30/35°C;
- Power supply: 380V 3N-50Hz; allowable voltage fluctuation: ±10%;
- If other related parameters of the unit are needed, contact the factory;
- The specifications are subject to change due to product improvement without prior notice.

Performance Parameters of Water Source Heat Pump Unit (Underground Water)

Model TWS-MD W4	Cooling capacity kW	Heating capacity kW	Cooling power input kW	Heating power input kW	Compressor Qty	Number of energy regulation levels	Cold and hot water-side heat exchanger				Underground water-side heat exchanger			
							Water pipe diameter	Water flow m ³ /h	Water pressure drop kPa	Connection mode	Water pipe diameter	Water flow m ³ /h	Water pressure drop kPa	Connection mode
20	78.3	83.4	13.6	18.3	2	0-100%, 2 levels	DN50	13.5	40	Flexible clamp	DN65	8.1	7	Flexible clamp
30	116.5	127.0	20.3	28.2	2	0-100%, 2 levels	DN50	20.0	49		DN65	12.0	13	
40	150.0	163.9	26.4	36.1	2	0-100%, 2 levels	DN65	25.8	63		DN80	15.5	22	

Model TWS-MD W4	Compressor Type	Startup mode	Maximum running current A	Dimensions			Refrigeration system				Lubricant model	Weight	
				Length (mm)	Width (mm)	Height (mm)	Refrigerant	System quantity	Control mode	Charge amount kg		Shipping weight	Operating weight
20	Hermetic scroll compressor	Direct starting	48.0	1880	660	1380	R410A	2	EXV	12	RL32-3MAF	470	500
30			71.9	1880	660	1490		2		14.5		520	555
40			95.8	1880	740	1590		2		18		630	670

Notes:

- The above data is obtained based on nominal conditions of the unit:
Cooling mode: inlet/outlet chilled water temperature 12/7°C; inlet/outlet underground water temperature 18/29°C;
Heating mode: outlet hot water temperature 45°C; inlet underground water temperature 15°C;
- Power supply: 380V 3N-50Hz; allowable voltage fluctuation: ±10%;
- If other related parameters of the unit are needed, contact the factory;
- The specifications are subject to change due to product improvement without prior notice

Performance Parameters of Water Source Heat Pump Unit (Geothermal)

Model TWS-MD G4	Cooling capacity kW	Heating capacity kW	Cooling power input kW	Heating power input kW	Compressor Qty	Number of energy regulation levels	Cold and hot water heat exchanger				Underground water loop heat exchanger			
							Water pipe diameter	Water flow m ³ /h	Water pressure drop kPa	Connection mode	Water pipe diameter	Water flow m ³ /h	Water pressure drop kPa	Connection mode
20	75.6	81.2	13.7	18.3	2	0-100%, 2 levels	DN50	13.0	40	Flexible clamp	DN65	16.3	25	Flexible clamp
30	113.4	121.2	20.5	28.1	2	0-100%, 2 levels	DN50	19.5	48		DN65	24.4	50	
40	149.2	154.2	27.1	36.0	2	0-100%, 2 levels	DN65	25.7	63		DN80	32.1	87	

Model TWS-MD G4	Compressor Type	Startup mode	Maximum running current A	Dimensions			Refrigeration system				Lubricant model	Weight	
				Length (mm)	Width (mm)	Height (mm)	Refrigerant	System quantity	Control mode	Charge amount kg		Shipping weight	Operating weight
20	Hermetic scroll compressor	Direct starting	48.0	1880	660	1380	R410A	2	EXV	12	RL32- 3MAF	470	500
30			71.9	1880	660	1490		2		14.5		520	555
40			95.8	1880	740	1590		2		18		630	670

Notes:

- The above data is obtained based on nominal conditions of the unit
Cooling mode: inlet/outlet chilled water temperature 12/7°C; inlet/outlet geothermal water temperature 25/30°C;
Heating mode: outlet hot water temperature 45°C; inlet geothermal water temperature 10°C;
- When the outlet geothermal water temperature is lower than 3°C, glycol solution needs to be added. Refer to Recommended Glycol Solution Concentration for details;
- Power supply: 380V 3N-50Hz; allowable voltage fluctuation: ±10%;
- If other related parameters of the unit are needed, contact the factory;
- The specifications are subject to change due to product improvement without prior notice.

Recommended Glycol Solution Concentration

Water Outlet Temperature °C	3 ~ 0	0 ~ -5	-5 ~ -10
Recommended Mass Concentration %	20	25	35

Corrected Technical Parameters under Variable Operating Condition

Corrected Technical Parameters of Cooling-only Unit under Variable Operating Condition

Model	Chilled water outlet temperature °C	Cooling water inlet temperature °C							
		20		25		30		35	
		Cooling capacity	Power input	Cooling capacity	Power input	Cooling capacity	Power input	Cooling capacity	Power input
TWS-MDC4	5	1.026	0.813	0.980	0.895	0.931	0.999	0.874	1.123
	6	1.060	0.814	1.017	0.897	0.966	1.000	0.905	1.123
	7	1.095	0.817	1.052	0.898	1.000	1.000	0.940	1.123
	8	1.132	0.818	1.086	0.899	1.034	1.001	0.974	1.123
	9	1.169	0.821	1.123	0.902	1.072	1.003	1.009	1.124
	10	1.206	0.824	1.160	0.904	1.106	1.004	1.046	1.124

Corrected Technical Parameters of Water Source Heat Pump Unit under Variable Cooling Operating Condition (Underground Water)

Model	Chilled water outlet temperature °C	Underground water inlet temperature °C											
		13		15		18		20		23		25	
		Cooling capacity	Power input	Cooling capacity	Power input	Cooling capacity	Power input	Cooling capacity	Power input	Cooling capacity	Power input	Cooling capacity	Power input
TWS-MDW4	5	1.031	0.910	0.980	0.954	0.939	0.998	0.908	1.037	0.885	1.097	0.870	1.142
	6	1.061	0.910	1.010	0.956	0.969	1.000	0.939	1.039	0.916	1.098	0.901	1.144
	7	1.092	0.912	1.041	0.958	1.000	1.000	0.969	1.042	0.949	1.100	0.931	1.146
	8	1.125	0.914	1.074	0.958	1.033	1.002	1.003	1.044	0.980	1.104	0.964	1.148
	9	1.158	0.917	1.107	0.960	1.066	1.004	1.036	1.047	1.013	1.105	0.997	1.151
	10	1.196	0.917	1.142	0.961	1.102	1.005	1.071	1.051	1.048	1.109	1.031	1.153

Corrected Technical Parameters of Water Source Heat Pump Unit under Variable Heating Operating Condition (Underground Water)

Model	Hot water outlet temperature °C	Underground water inlet temperature °C											
		13		14		15		16		17		18	
		Heating capacity	Power input	Heating capacity	Power input	Heating capacity	Power input	Heating capacity	Power input	Heating capacity	Power input	Heating capacity	Power input
TWS-MDW4	40	1.000	0.888	1.035	0.889	1.074	0.889	1.109	0.890	1.147	0.891	1.188	0.893
	43	0.959	0.953	0.994	0.953	1.029	0.953	1.068	0.954	1.103	0.955	1.141	0.956
	45	0.929	0.999	0.965	0.999	1.000	1.000	1.035	1.000	1.074	1.001	1.109	1.002
	48	0.885	1.073	0.918	1.073	0.950	1.073	0.985	1.073	1.024	1.074	1.059	1.075
	50	0.853	1.127	0.885	1.127	0.918	1.127	0.953	1.127	0.985	1.127	1.024	1.127
	55	0.765	1.269	0.794	1.264	0.826	1.264	0.859	1.264	0.891	1.264	0.924	1.264

Corrected Technical Parameters of Water Source Heat Pump Unit under Variable Cooling Operating Condition (Geothermal)

Model	Chilled water outlet temperature °C	Geothermal water inlet temperature °C													
		10		15		20		25		30		35		40	
		Cooling capacity	Power input	Cooling capacity	Power input	Cooling capacity	Power input	Cooling capacity	Power input	Cooling capacity	Power input	Cooling capacity	Power input	Cooling capacity	Power input
TWS-MDG4	5	1.025	0.767	1.003	0.828	0.973	0.905	0.934	0.997	0.888	1.112	0.833	1.250	0.776	1.408
	6	1.057	0.770	1.036	0.830	1.005	0.906	0.967	0.998	0.921	1.113	0.866	1.250	0.803	1.408
	7	1.096	0.771	1.074	0.833	1.041	0.910	1.000	1.000	0.954	1.113	0.896	1.250	0.836	1.406
	8	1.128	0.775	1.104	0.834	1.074	0.911	1.036	1.002	0.986	1.115	0.929	1.250	0.866	1.406
	9	1.169	0.778	1.142	0.837	1.109	0.914	1.068	1.005	1.019	1.117	0.962	1.252	0.899	1.406
	10	1.178	0.781	1.180	0.840	1.148	0.917	1.107	1.006	1.055	1.118	0.997	1.252	0.929	1.408

Corrected Technical Parameters of Water Source Heat Pump Unit under Variable Heating Operating Condition (Geothermal)

Model	Hot water outlet temperature °C	Geothermal water inlet temperature °C													
		-5		0		5		10		15		20		25	
		Heating capacity	Power input	Heating capacity	Power input	Heating capacity	Power input	Heating capacity	Power input	Heating capacity	Power input	Heating capacity	Power input	Heating capacity	Power input
TWS-MDG4	40	0.569	0.899	0.718	0.894	0.887	0.890	1.074	0.888	1.285	0.889	1.518	0.897	1.764	0.903
	42	0.548	0.946	0.695	0.900	0.859	0.934	1.046	0.930	1.250	0.931	1.479	0.938	1.725	0.944
	45	0.517	1.005	0.657	1.012	0.817	1.004	1.000	1.000	1.197	1.000	1.423	1.004	1.669	1.009
	46	/	/	0.644	1.037	0.803	1.029	0.982	1.024	1.180	1.023	1.401	1.028	1.648	1.036
	48	/	/	0.618	1.089	0.775	1.081	0.947	1.075	1.141	1.073	1.359	1.077	1.606	1.081
	50	/	/	0.595	1.130	0.743	1.133	0.912	1.127	1.102	1.127	1.313	1.127	1.560	1.130
	55	/	/	/	/	0.637	1.267	0.817	1.269	0.993	1.264	1.190	1.269	1.437	1.277

Module Dimensions

TWS20MDC(W/G)4

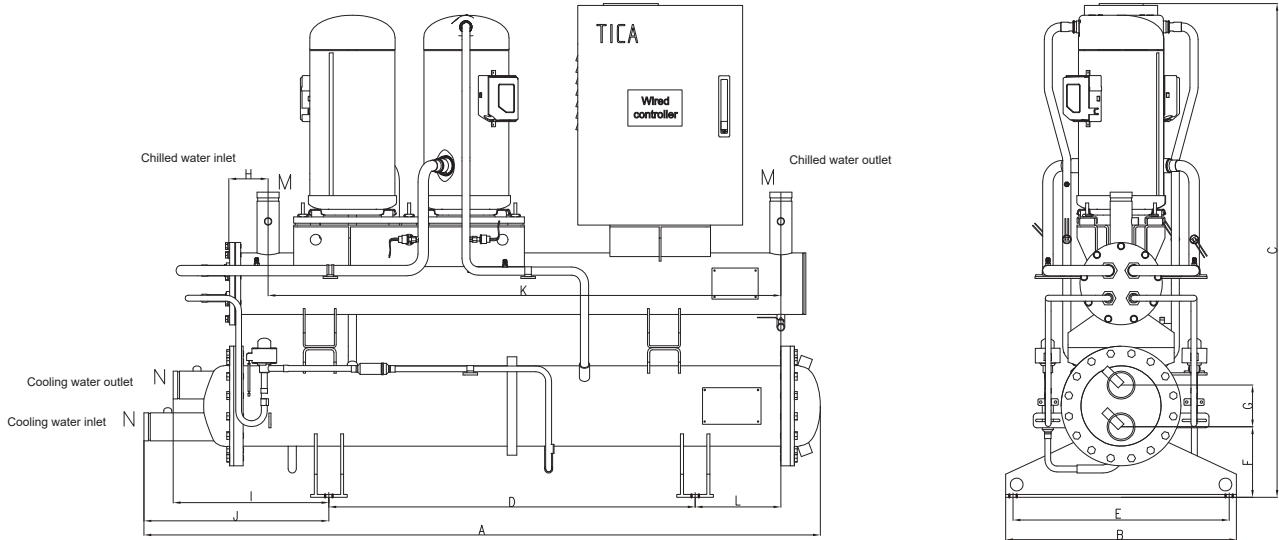

TWS30MDC(W/G)4

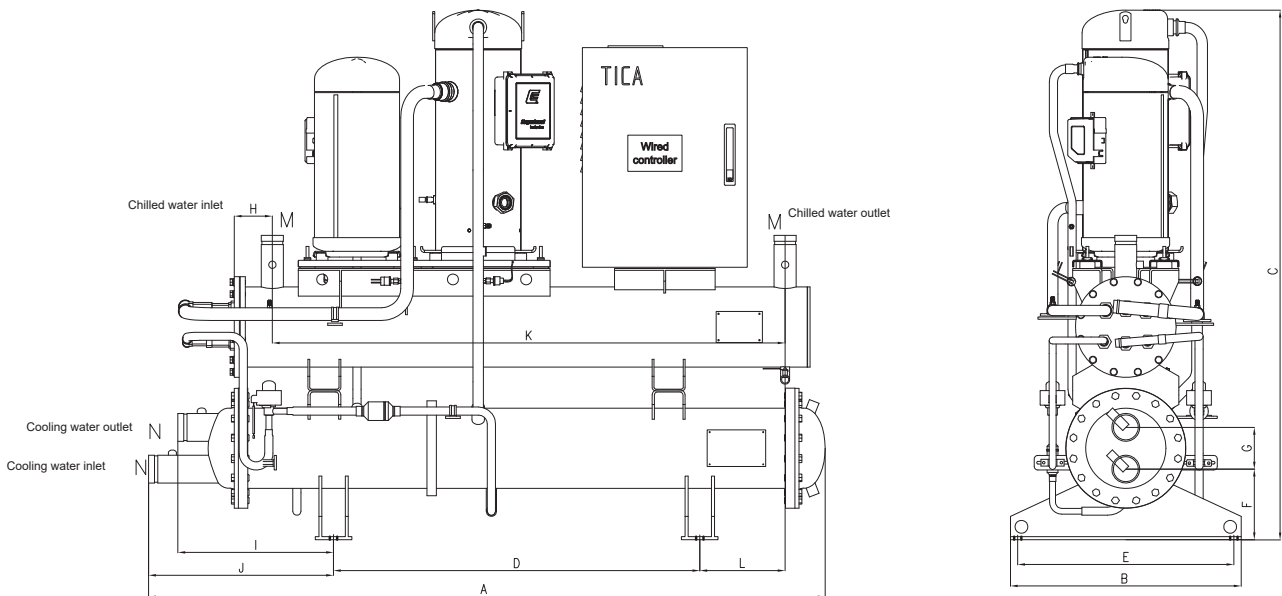

TWS40MDC(W/G)4

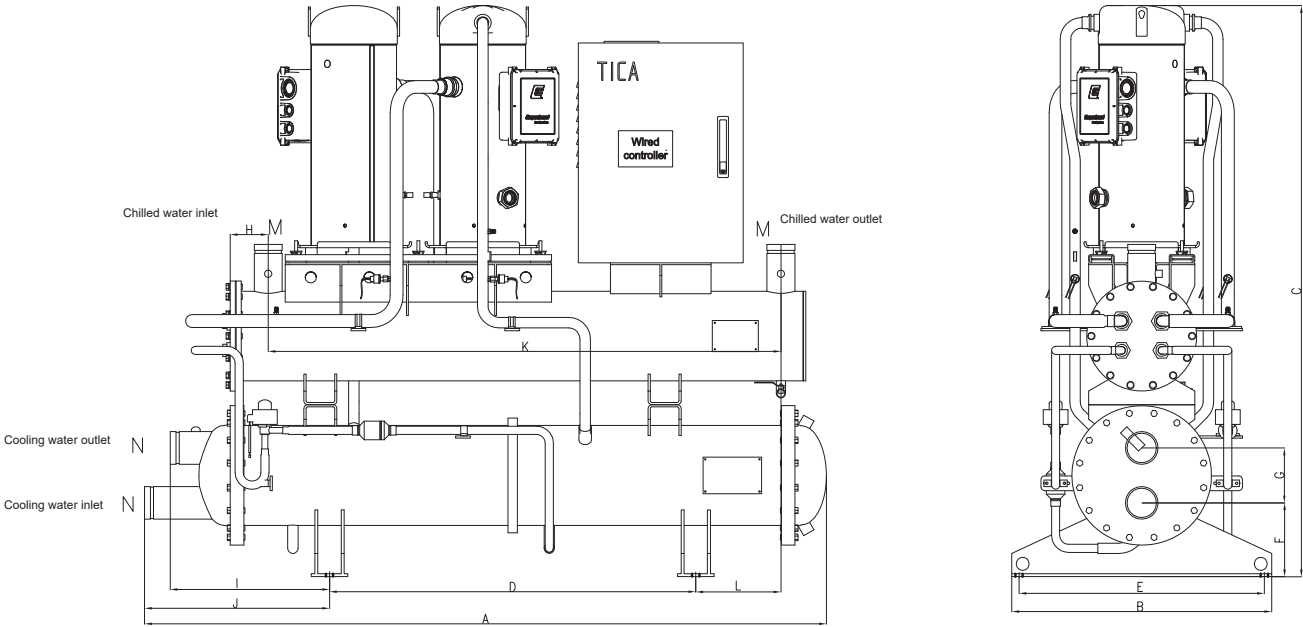

Model	A	B	C	D	E	F	G	H	I	J	K	L	M(DN)	N(DN)
TWS20MDC(W/G)4	1880	660	1380	1000	590	192	114	105	425	505	1400	234	50	65
TWS30MDC(W/G)4	1880	660	1490	1000	590	192	114	105	425	505	1400	234	50	65
TWS40MDC(W/G)4	1900	740	1590	1000	670	202	150	105	435	505	1400	234	65	80

Standard Duct -TCR

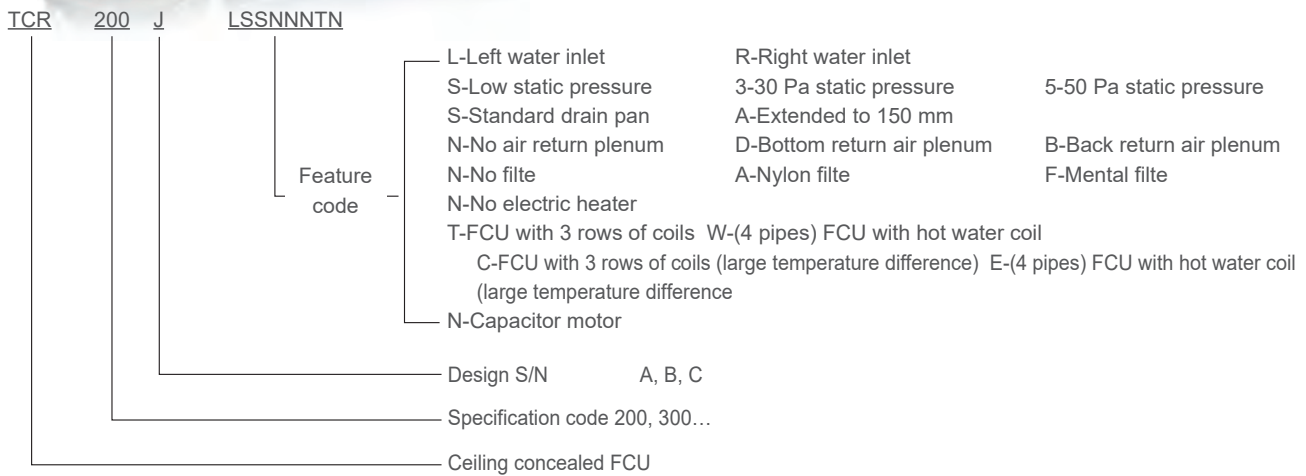

1. Different ES for option

12Pa,30Pa,50Pa is standard,and 80Pa can be customized.

2. Multiple coils design

Two-pipe system (3 rows) and four-pipe system (3+1) are available.

3. Return air purifiers as optional to make environment clea

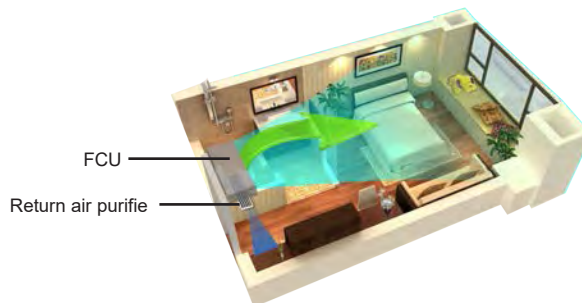
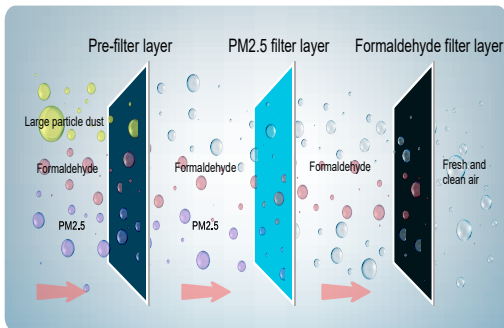

Operating principles:

The pre-filter layer removes hair, dust, and large particles from the air; the professional PM2.5 filter layer adopts the unique electrostatic technology to remove PM2.5 from the air through physical adsorption measures, without causing ozone hazard; the capture agent on the formaldehyde filter surface shows a formaldehyde removal capacity more powerful than that of the traditional activated carbon net, and converts the formaldehyde in air into a kind of safe and harmless substance through chemical reaction, instead of releasing it into the room with air and without leading to secondary pollution because of filtration adsorption and heating

Standard Duct (3 Rows)

Model: TCR		200J	300J	400J	500J	600J	700J	800J	1000J	1200J	1400J	
Rated Air Flow (m ³ /h)	High	340	510	680	850	1020	1190	1360	1700	2040	2380	
	Medium	270	380	510	640	780	880	1030	1290	1540	1850	
	Low	190	280	340	450	560	610	740	890	1040	1255	
Cooling Capacity (W)	High	2210	3200	4150	5000	5950	6600	8100	9100	11250	13000	
	Medium	1990	2782	3570	4197	5200	5600	6882	8200	9613	11700	
	Low	1635	2304	2950	3298	4200	4600	5749	6700	7403	7560	
Sensible Cooling Capacity (W)	High	1590	2285	2880	3570	4200	4700	5880	6700	8260	9750	
	Medium	1400	1920	2420	2930	3570	3900	4880	5700	6935	8280	
	Low	1050	1555	1930	2210	2900	3200	3935	4500	5120	5945	
Heating Capacity (Water Inlet: 60°C) (W)		High	3500	5200	6500	7870	9800	10900	13570	14900	22100	
Heating Capacity (Water Inlet: 45°C) (W)		High	2210	3200	4150	5000	5950	6600	8100	9100	11250	
Power Input (W)	12Pa	High	30	45	55	72	93	100	128	147	183	221
		Medium	27	36	43	58	80	97	112	130	165	198
		Low	23	30	35	48	68	78	95	110	136	165
	30 Pa	High	38	55	65	82	100	120	148	169	206	245
		Medium	32	45	50	64	80	105	133	160	195	230
		Low	27	33	37	53	70	90	128	140	170	195
	50 Pa	High	45	64	75	91	114	130	165	200	243	290
		Medium	36	50	65	86	105	110	150	190	230	270
		Low	30	42	55	73	90	96	122	170	200	250
Sound Level (dB(A))	Low Static Pressure (12Pa)	High	35	38	39	41	45	46	46	47	49	51
		Medium	28.5	30	31	32	37	40	40	41	44	47
		Low	20.5	21	22	24	28	31	31	32	34	35
	30 Pa	High	38	41	42.5	45	46.5	48	47	49	51	52
		Medium	30.5	32	34	36.5	38.5	41	41	43	46	48
		Low	23	22	22	27.5	30	32	32	34	35	36
	50 Pa	High	42	43	45	47	49	50	50	52	53	53
		Medium	35.5	36	38	38.5	40	44	44	46	47.5	49
		Low	29	28	28	29	31	36	36	38	40	42
Fan	Type	Forward-curved multi-blade double inlet centrifugal fan										
Motor	Type	Single-phase capacitor motor										
Heat Exchanger	Structure Type	Efficient double-flanged aluminum fins and copper tubes, expanded into										
	Maximum Operating Pressure (MPa)	1.6										
	Water Inlet/Outlet Pipe Diameter (inch)	Rc3/4 (Taper Pipe Female Threaded)										
	Water Flow (m ³ /h)	0.42	0.55	0.72	0.87	1.05	1.12	1.39	1.67	1.9	2.23	
Water Resistance	kPa	25	25	30	30	40	40	40	40	40	50	
Drain Pan	Condensate Water Pipe Diameter (inch)	Rc3/4 (Taper Pipe Male Threaded)										
Dimensions (Without Return Air Plenum)	Length (mm)	695	845	930	995	1085	1235	1530	1530	1795	1795	
	Width (mm)	470	470	470	470	470	470	470	470	490	490	
	Height (mm)	230	230	230	230	230	230	230	230	250	250	
Net Weight	Air Return Plenum (Excluded) (kg)	10.5	12.5	14.5	16	17	18.5	22	25	30	31.5	
	Air Return Plenum (Included) (kg)	12.5	15.5	17.5	19	20	22.5	26	29	36	37.5	

★ Note:

- Cooling: supply water and return water temperatures 7/12°C; the dry/wet bulb temperature of air inlet is 27/19.5°C;
- Heating: supply water is 60°C or 45°C, water quantity being the same as during cooling; air return conditions: the dry bulb temperature of air inlet is 21°C;
- In the table, low static pressure indicates the air outlet static pressure at 0Pa (with air outlet and filter) and at 12Pa without air outlet and filter)
- The air flow in the table is obtained when the unit is running in dry state and the dry bulb temperature of air inlet is 20°C;
- Left & right swing manner can be adjusted on site. After adjustment, the cooling capacity and heating capacity should be multiplied by the correction factor 0.9;

Standard Duct (3+1 Rows)

Model: TCR		200J	300J	400J	500J	600J	700J	800J	1000J	1200J	1400J	
Rated Air Flow (m³/h)	High	340	500	680	830	1000	1140	1340	1700	2040	2380	
	Medium	270	380	510	620	750	880	1030	1290	1540	1975	
	Low	190	240	340	420	560	610	720	890	1040	1255	
Cooling Capacity (W)	High	2210	3200	4150	4800	5950	6800	7900	9200	10275	12600	
	Medium	1890	2782	3570	4150	5200	5900	6900	8000	8500	11000	
	Low	1500	2304	2950	3400	4200	5000	5800	6700	7450	9500	
Sensible Cooling Capacity (W)	High	1590	2285	2880	3400	4200	4700	5750	6600	7400	9400	
	Medium	1350	1920	2420	2880	3570	3900	4800	5500	6200	7900	
	Low	1050	1555	1930	2210	2900	3200	3700	4200	4930	6200	
Heating Capacity (60/50°C) (W)	High	2050	3000	3850	4500	5200	6300	7550	8400	9800	10800	
Heating Capacity (45/40°C) (W)	High	1300	1800	2300	2700	3200	3700	4500	5100	6100	6600	
Power Input (W)	12Pa	High	30	45	55	72	93	100	128	147	183	221
		Medium	27	36	43	58	80	97	112	130	165	198
		Low	23	30	35	48	68	78	95	110	136	165
	30 Pa	High	38	55	65	82	100	120	148	169	206	245
		Medium	32	45	50	64	80	105	133	160	195	230
		Low	27	33	37	53	70	90	128	140	170	195
	50 Pa	High	45	64	75	91	114	130	165	200	243	290
		Medium	36	50	65	86	105	110	150	190	230	270
		Low	30	42	55	73	90	96	122	170	200	250
Sound Level (dB(A))	12Pa	High	36.5	38	39	42	45	46	46	47	49	51
		Medium	30	30	31	33	38	41	41	41	44	47
		Low	21	21	22	25	29	32	32	33	34	36
	30 Pa	High	38.5	41	42.5	45	46.5	48	47	49	51	52.5
		Medium	32	32.5	34	37.5	39	42	41	43	46	48
		Low	23	23	24	28.5	30	33	32	34	35.5	37
	50 Pa	High	42	43.5	45	47	49	50	50	52	53	53.5
		Medium	36	37	38	39.5	41	45	45	46.5	47.5	50
		Low	29	29	30	30	32	36	36	38	41	43
Fan	Type	Forward-curved multi-blade double inlet centrifugal fan										
Motor	Type	Single-phase capacitor motor										
Heat Exchanger	Structure Type	Efficient double-flanged aluminum fins and copper tubes, expanded into										
	Maximum Operating Pressure (MPa)	1.6										
	Water Inlet/Outlet Pipe Diameter (inch)	Rc3/4 (Taper Pipe Female Threaded)										
Water Flow	Cooling Mode (m³/h)	0.39	0.63	0.73	0.86	1.04	1.17	1.39	1.65	1.9	2.04	
	Heating Mode (60/50°C) (m³/h)	0.21	0.29	0.33	0.42	0.47	0.55	0.66	0.72	0.88	0.95	
	Heating Mode (45/40°C) (m³/h)	0.22	0.31	0.41	0.47	0.53	0.63	0.76	0.86	1.04	1.13	
Water Resistance	Cooling Mode (kPa)	25	25	30	30	40	40	40	40	40	50	
	Heating Mode (60/50°C) (kPa)	10	10	20	25	15	20	30	20	30	35	
	Heating Mode (45/40°C) (kPa)	10	15	25	30	20	25	40	25	40	50	
Drain Pan	Condensate Water Pipe Diameter (inch)	Rc3/4 (Taper Pipe Male Threaded)										
Dimensions (Without Return Air Plenum)	Length (mm)	695	845	930	995	1085	1235	1530	1530	1795	1795	
	Width (mm)	470	470	470	470	470	470	470	470	490	490	
	Height (mm)	230	230	230	230	230	230	230	230	250	250	
Net weight	Air Return Plenum (Excluded) (kg)	11.5	13.5	15.5	17	19	20	24	27	33	35	
	Air Return Plenum (Included) (kg)	13.5	16.5	18.5	20	22	24	28	31	39	41	

★ Note:

- Cooling: supply water and return water temperatures 7/12°C; the dry/wet bulb temperature of air inlet is 27/19.5°C;
- Heating: supply water is 60°C or 45°C, water quantity being the same as during cooling; air return conditions: the dry bulb temperature of air inlet is 21°C;
- In the table, low static pressure indicates the air outlet static pressure at 0Pa (with air outlet and filter) and at 12Pa without air outlet and filter)
- The air flow in the table is obtained when the unit is running in dry state and the dry bulb temperature of air inlet is 20°C;
- Left & right swing manner can be adjusted on site. After adjustment, the cooling capacity and heating capacity should be multiplied by the correction factor 0.9;

Standard Duct (District Cooling, 3 Rows)

Model: TCR		200J	300J	400J	500J	600J	700J	800J	1000J	1200J	1400J	
Rated Air Flow (m ³ /h)	High	340	510	680	850	1020	1190	1360	1700	2040	2380	
	Medium	270	380	510	640	780	880	1030	1290	1540	1850	
	Low	190	280	340	450	560	610	740	890	1040	1255	
Cooling Capacity (W)	High	2200	3100	4000	4800	5750	6500	8000	9100	11250	12800	
	Medium	1900	2700	3500	4100	5000	5500	6800	8200	9600	11000	
	Low	1600	2250	2900	3200	4000	4500	5700	6700	7400	7500	
Sensible Cooling Capacity (W)	High	1500	2200	2800	3500	4100	4700	5800	6700	8200	9700	
	Medium	1400	1900	2400	2900	3500	3900	4800	5700	6900	8200	
	Low	1050	1500	1900	2200	2800	3200	3900	4500	5100	5900	
Heating Capacity (60/50°C) (W)	High	3400	4850	6100	7500	9000	10200	12300	14500	17500	19900	
Heating Capacity (45/40°C) (W)	High	2100	3000	3850	4600	5500	6300	7700	8800	10800	12300	
Power Input (W)	12Pa	High	30	45	55	72	93	100	128	147	183	221
		Medium	27	36	43	58	80	97	112	130	165	198
		Low	23	30	35	48	68	78	95	110	136	165
	30 Pa	High	38	55	65	82	100	120	148	169	206	245
		Medium	32	45	50	64	80	105	133	160	195	230
		Low	27	33	37	53	70	90	128	140	170	195
	50 Pa	High	45	64	75	91	114	130	165	200	243	290
		Medium	36	50	65	86	105	110	150	190	230	270
		Low	30	42	55	73	90	96	122	170	200	250
Sound Level (dB(A))	12Pa	High	35	38	39	41	45	46	46	47	49	51
		Medium	28.5	30	31	32	37	40	40	41	44	47
		Low	20.5	21	22	24	28	31	31	32	34	35
	30 Pa	High	38	41	42.5	45	46.5	48	47	49	51	52
		Medium	30.5	32	34	36.5	38.5	41	41	43	46	48
		Low	23	22	22	27.5	30	32	32	34	35	36
	50 Pa	High	42	43	45	47	49	50	50	52	53	53
		Medium	35.5	36	38	38.5	40	44	44	46	47.5	49
		Low	29	28	28	29	31	36	36	38	40	42
Fan	Type	Forward-curved multi-blade double inlet centrifugal fan										
Motor	Type	Single-phase capacitor motor										
Heat Exchanger	Maximum Operating Pressure (MPa)	Efficient double-flanged aluminum fins and copper tubes, expanded into										
	Water Inlet/Outlet Pipe Diameter	1.6										
	Water Inlet/Outlet Pipe Diameter (inch)	Rc3/4 (Taper Pipe Female Threaded)										
	Water Flow m ³ /h	0.24	0.33	0.45	0.5	0.61	0.7	0.83	0.99	1.2	1.42	
Water Resistance	kPa	25	25	30	25	40	30	30	40	40	40	
Drain Pan	Condensate Water Pipe Diameter (inch)	Rc3/4 (Taper Pipe Male Threaded)										
Dimensions (Without Return Air Plenum)	Length (mm)	695	845	930	995	1085	1235	1530	1530	1795	1795	
	Width (mm)	470	470	470	470	470	470	470	470	490	490	
	Height (mm)	230	230	230	230	230	230	230	230	250	250	
Net weight	Air Return Plenum (Excluded) (kg)	10.5	12.5	14.5	16	17	18.5	22	25	30	31.5	
	Air Return Plenum (Included) (kg)	12.5	15.5	17.5	19	20	22.5	26	29	36	37.5	

★ Note:

- Cooling: supply water and return water temperatures 5/13°C; the dry/wet bulb temperature of air inlet is 27/19.5°C;
- Heating: supply water is 60°C or 45°C, water quantity being the same as during cooling; air return conditions: the dry bulb temperature of air inlet is 21°C;
- In the table, low static pressure indicates the air outlet static pressure at 0Pa (with air outlet and filter) and at 12Pa without air outlet and filter)
- The air flow in the table is obtained when the unit is running in dry state and the dry bulb temperature of air inlet is 20°C;
- Left & right swing manner can be adjusted on site. After adjustment, the cooling capacity and heating capacity should be multiplied by the correction factor 0.9;

Standard Duct (District Cooling, 3+1 Rows)

Model: TCR		200J	300J	400J	500J	600J	700J	800J	1000J	1200J	1400J	
Rated Air Flow (m³/h)	High	340	500	680	830	1000	1140	1340	1700	2040	2380	
	Medium	270	380	510	620	750	880	1030	1290	1540	1975	
	Low	190	240	340	420	560	610	720	890	1040	1255	
Cooling Capacity (W)	High	2200	3100	4000	4800	5750	6500	8000	9100	11250	12800	
	Medium	1900	2700	3500	4100	5000	5500	6800	8200	9600	11000	
	Low	1600	2250	2900	3200	4000	4500	5700	6700	7400	7500	
Sensible Cooling Capacity (W)	High	1500	2200	2800	3500	4100	4700	5800	6700	8200	9700	
	Medium	1400	1900	2400	2900	3500	3900	4800	5700	6900	8200	
	Low	1050	1500	1900	2200	2800	3200	3900	4500	5100	5900	
Heating Capacity (60/50°C) (W)	High	2050	3000	3850	4500	5200	6300	7550	8400	9800	10800	
Heating Capacity (45/40°C) (W)	High	1300	1800	2300	2700	3200	3700	4500	5100	6100	6600	
Power Input (W)	12Pa	High	30	45	55	72	93	100	128	147	183	221
		Medium	27	36	43	58	80	97	112	130	165	198
		Low	23	30	35	48	68	78	95	110	136	165
	30 Pa	High	38	55	65	82	100	120	148	169	206	245
		Medium	32	45	50	64	80	105	133	160	195	230
		Low	27	33	37	53	70	90	128	140	170	195
	50 Pa	High	45	64	75	91	114	130	165	200	243	290
		Medium	36	50	65	86	105	110	150	190	230	270
		Low	30	42	55	73	90	96	122	170	200	250
Sound Level (dB(A))	12Pa	High	36.5	38	39	42	45	46	46	47	49	51
		Medium	30	30	31	33	38	41	41	41	44	47
		Low	21	21	22	25	29	32	32	33	34	36
	30 Pa	High	38.5	41	42.5	45	46.5	48	47	49	51	52.5
		Medium	32	32.5	34	37.5	39	42	41	43	46	48
		Low	23	23	24	28.5	30	33	32	34	35.5	37
	50 Pa	High	42	43.5	45	47	49	50	50	52	53	53.5
		Medium	36	37	38	39.5	41	45	45	46.5	47.5	50
		Low	29	29	30	30	32	36	36	38	41	43
Fan	Type	Forward-curved multi-blade double inlet centrifugal fan										
Motor	Type	Single-phase capacitor motor										
Heat Exchanger	Structure Type	Efficient double-flanged aluminum fins and copper tubes, expanded into										
	Maximum Operating Pressure (MPa)	1.6										
	Water Inlet/Outlet Pipe Diameter (inch)	Rc3/4 (Taper Pipe Female Threaded)										
Water Flow	Cooling Mode (m³/h)	0.24	0.33	0.45	0.5	0.61	0.7	0.83	0.99	1.2	1.42	
	Heating Mode (60/50°C) (m³/h)	0.21	0.29	0.33	0.42	0.47	0.55	0.66	0.72	0.88	0.95	
	Heating Mode (45/40°C) (m³/h)	0.22	0.31	0.41	0.47	0.53	0.63	0.76	0.86	1.04	1.13	
Water Resistance	Cooling Mode (kPa)	25	25	30	25	40	30	30	40	40	40	
	Heating Mode (60/50°C) (kPa)	10	10	20	25	15	20	30	20	30	35	
	Heating Mode (45/40°C) (kPa)	10	15	25	30	20	25	40	25	40	50	
Drain Pan	Condensate Water Pipe Diameter (inch)	Rc3/4 (Taper Pipe Male Threaded)										
Dimensions (Without Return Air Plenum)	Length (mm)	695	845	930	995	1085	1235	1530	1530	1795	1795	
	Width (mm)	470	470	470	470	470	470	470	470	490	490	
Net Weight	Height (mm)	230	230	230	230	230	230	230	230	250	250	
	Air Return Plenum (Excluded) (kg)	11.5	13.5	15.5	17	19	20	24	27	33	35	
	Air Return Plenum (Included) (kg)	13.5	16.5	18.5	20	22	24	28	31	39	41	

★ Note:

- Cooling: supply water and return water temperatures 5/13°C; the dry/wet bulb temperature of air inlet is 27/19.5°C;
- Heating: supply water and return water temperatures 60/50°C or 45/40°C; air return conditions: the dry bulb temperature of air inlet is 21°C;
- In the table, low static pressure indicates the air outlet static pressure at 0Pa (with air outlet and filter) and at 12Pa without air outlet and filter)
- The air flow in the table is obtained when the unit is running in dry state and the dry bulb temperature of air inlet is 20°C;
- For a 4-pipe unit, there are 3 rows of cooling coils and 1 row of heating coil;

Dimension

Standard Duct (3 Rows/District Cooling, 3 Rows)

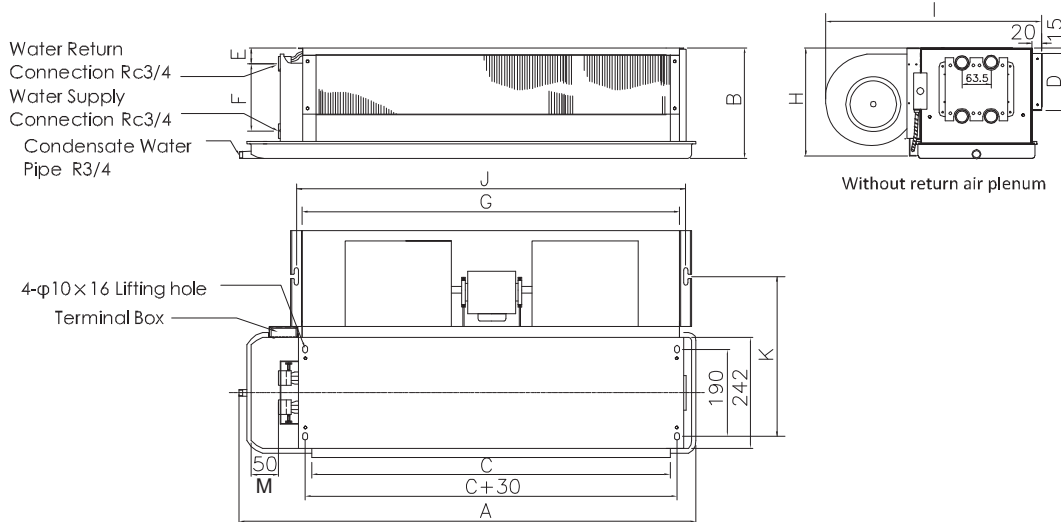

TCR	A	B	C	D	E	F	G	H	I	J	K	M	Motor Quantity	Fan Quantity
200	695	230	435	135	54	118	477	225	470	504	346	50	1	1
300	845	230	570	135	54	118	610	225	470	637	346	65	1	2
400	930	230	670	135	54	118	712	225	470	739	346	50	1	2
500	995	230	730	135	54	118	772	225	470	799	346	55	1	2
600	1085	230	825	135	54	118	867	225	470	894	346	50	1	2
700	1235	230	970	135	54	118	1012	225	470	1039	346	55	1	2
800	1530	230	1215	135	54	118	1257	225	470	1284	346	105	1	3
1000	1530	230	1255	135	54	118	1297	225	470	1324	346	65	2	3
1200	1795	250	1510	135	54	118	1552	240	490	1579	357	45	2	4
1400	1795	250	1510	135	54	118	1552	240	490	1579	357	45	2	4

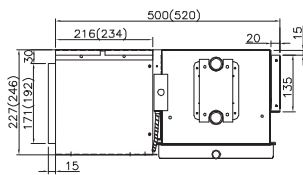

With back return air plenum (TCR200-1200)
 Dimensions in brackets for TCR1200

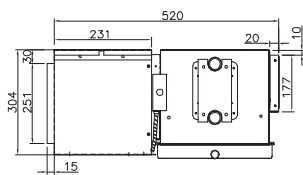

With back return air plenum (TCR1400)

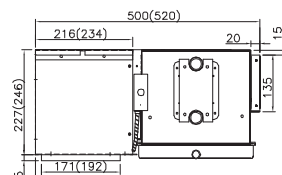

With bottom return air plenum (TCR200-1200)
 Dimensions in brackets for TCR1200

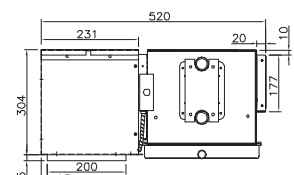

With bottom return air plenum (TCR1400)

TCR	Length of return air plenum	Length of plenum wind-gap
200	483.6	422
300	615.6	557
400	725.6	657
500	775.6	717
600	870.6	812
700	1015.6	957
800	1260.6	1202
1000	1300.6	1242
1200	1555.6	1497
1400	1634	1596

Standard Duct (3+1 Rows/District Cooling, 3+1 Rows)

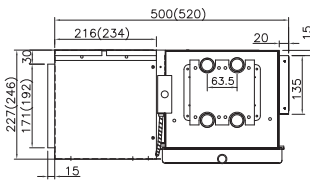
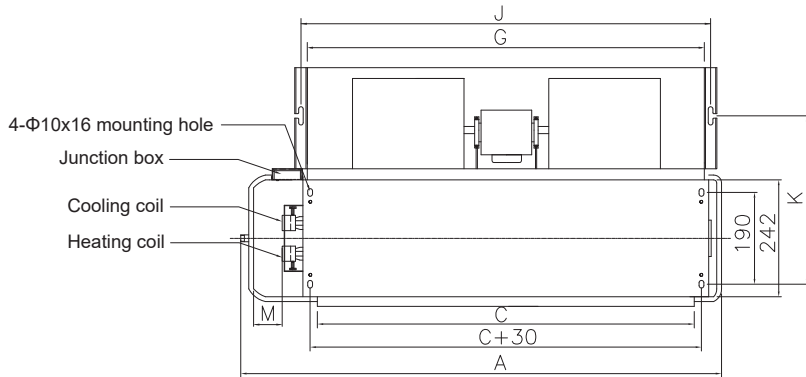
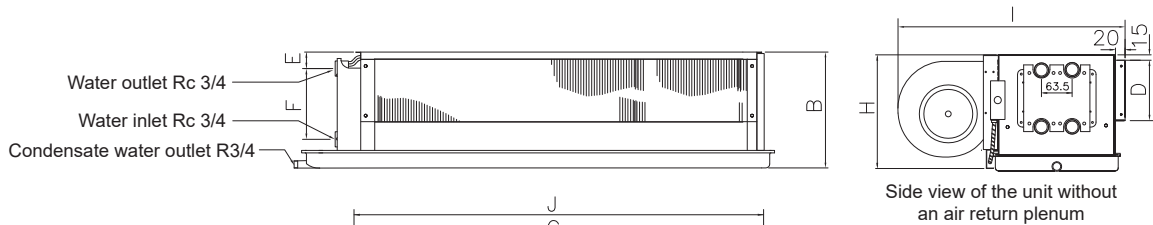

Side view of the unit with a rear air return plenum (models 200-1200)
Side view of the unit with a rear air return plenum (model 1400)

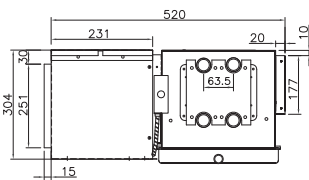

Side view of the unit with a rear air return plenum (models 1400)

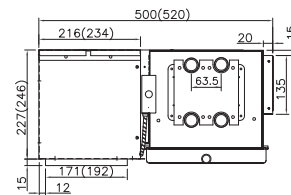

Side view of the unit with a bottom air return plenum (models 200-1200) (Dimensions in brackets are dimensions of model 1200)

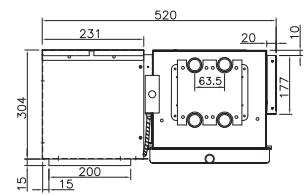

Side view of the unit with a bottom air return plenum (model 1400)

Model: TCR	A	B	C	D	E	F	G	H	I	J	K	M
200	695	230	435	135	54	118	477	225	470	504	346	50
300	845	230	570	135	54	118	610	225	470	637	346	65
400	930	230	670	135	54	118	712	225	470	739	346	50
500	995	230	730	135	54	118	772	225	470	799	346	55
600	1085	230	825	135	54	118	867	225	470	894	346	50
700	1235	230	970	135	54	118	1012	225	470	1039	346	55
800	1530	230	1215	135	54	118	1257	225	470	1284	346	105
1000	1530	230	1255	135	54	118	1297	225	470	1324	346	65
1200	1795	250	1510	135	54	118	1552	240	490	1579	357	45
1400	1795	250	1510	135	54	118	1552	240	490	1579	357	45

★ Note:

- The air return plenum unit with a filter screen does not have a air return flange onl , with other dimensions remaining the same.
- When vibration-absorbing lifting hooks are used for lifting the unit, tell the factory about it.

Silent Duct -TCRQ

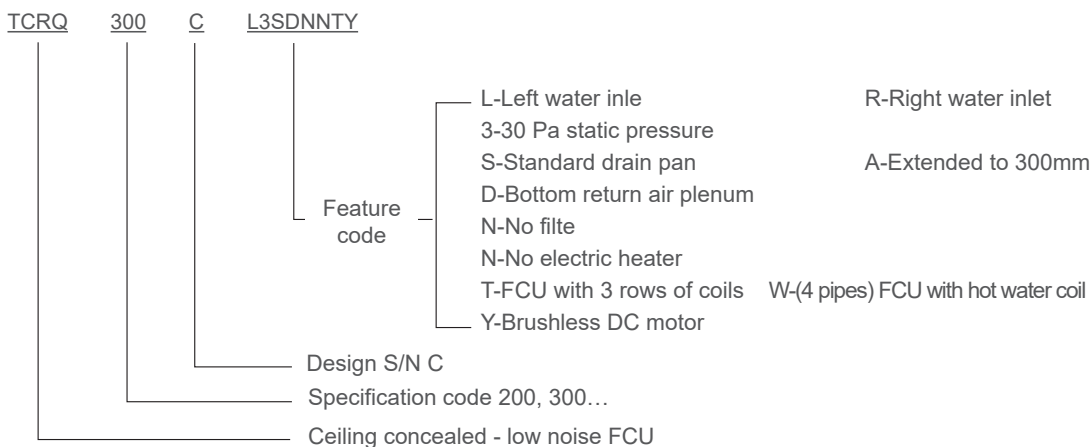
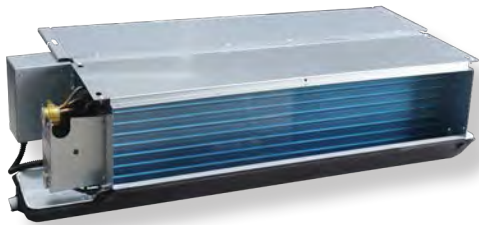

Remarks: The standard default static pressure of the TCRQ unit is 30 Pa, while, 12 Pa and 50 Pa static pressure can be adjusted on site.

1. Low Noise

- It adopts the stamping-formed wide impeller with imported hot dip galvanized steel sheet of high quality and the centrifugal (blade: forward-curved) fan of low speed, and features low noise, high efficiency and exquisite structure.
- It adopts the high quality rolling bearings with low noises and little vibration delivered by an international famous brand, which do not need to be maintained and can be used for a long time.
- It adopts the composite acoustical coating meeting environmental protection requirements. Anechoic layers with different interface shapes are provided between composite layers to improve the acoustic attenuation performance greatly.

Main technologies

- TICA's independently patented micro-perforated panel diversion assembly
- Eco-friendly flame retardant and anechoic material used in the FCU cavity
- Combined with the high efficiency motor by matching the centrifugal (blade: forward-curved) fan

2. Brushless DC motor as optional

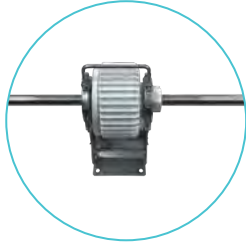

High efficiency and energy saving

- Low heat radiation, efficiencies up to 75% (in contrast to the 30%-40% of conventional AC motor), average power consumptions equal to 50%-70% of AC motor.
- Optional solutions of three-stage speed regulation and stepless speed regulation; the air conditioner operates with a partial load in 90% of the time; under the stepless regulation mode, the motor speed is adjusted based on actual demand to save energy and substantially increase the energy efficiency.

Low noise to ensure comfort

- Adopts the PWM sine wave control technology to achieve low vibration and noise; driver carrier frequency above 15k to eliminate high frequency noise and special groove type design to reduce low frequency noise.
- The output torque satisfies the load application characteristics of unit and keeps the unit in a highly stable status.

A wide range of applications, reliable and safe

- The LCD thermostat is stylish and can be used as a high-end thermostat in various types of TICA fan coils. The operating voltage is a globally applicable 90 VAC to 230 VAC. It is used to control the opening/closing of the pipeline system control components such as the fan coil pipeline valves to turn on/off the circulation media such as the cold and hot water sources of the pipeline, thus controlling regional temperature.

Intelligent control

- The thermostat with the RS485 interface is optional. It supports the Modbus communication protocol and can be used for linkage with the building automation system to implement the centralized operation management of remote automatic control and monitoring.
- The elegant thermostat is provided with an LCD screen to realize perfect fusion with building decoration.

3. Ultra-low noise, quiet and comfortable

- It adopts the forward curved centrifugal fan of low speed, and features low noise, high efficiency and exquisite structure. The motors use imported corrugated washers and advanced damping rotors with low vibration and noise.
- Combined with the high efficiency motor and the forward curved centrifugal fan, the unit is able to run quietly, thus greatly improving comfort.
- The unit's noise level is far below the national standard, reaching the industry leading level.

4. Compact, light, flexible and elegant

- The unit is compact in structure, lightweight and elegant in its entirety. The installation space is about 6% less than that of the standard fan coil. The ultra-thin design can meet the maximum requirements such as the effective floor height of the house.
- The return air plenum is equipped, which is installed on site.

Silent Duct (3 Rows)

TCRQ		300C	400C	500C	600C	700C	800C	1000C	1200C	
Rated Air Flow (m ³ /h)	High	510	680	850	1020	1190	1360	1700	2040	
	Medium	380	510	640	765	890	1020	1275	1530	
	Low	255	340	425	510	595	680	850	1020	
Cooling Capacity (W)	High	3200	4150	5000	5950	6600	8100	9100	11250	
	Medium	2782	3570	4197	5200	5600	6882	8200	9613	
	Low	2304	2950	3298	4200	4600	5749	6700	7403	
Sensible Cooling Capacity (W)	High	2285	2880	3570	4200	4700	5880	6700	8260	
	Medium	1920	2420	2930	3570	3900	4880	5700	6935	
	Low	1555	1930	2210	2900	3200	3935	4500	5120	
Heating Capacity (Water Inlet: 60°C) (W)		High	5200	6500	7870	9800	10900	13570	14900	18800
Heating Capacity (Water Inlet: 45°C) (W)		High	3200	4150	5000	5950	6600	8100	9100	11250
Power Input (W)	12Pa	High	17	24	34	47	47	54	72	99
		Medium	10	14	18	24	24	28	39	48
		Low	6	8	10	13	13	15	22	24
	30 Pa	High	23	33	44	57	57	68	90	119
		Medium	13	17	22	29	29	34	47	57
		Low	8	9	12	14	15	18	25	27
	50 Pa	High	31	42	53	68	71	87	111	143
		Medium	16	22	27	33	35	42	55	88
		Low	9	11	13	16	17	20	28	38
Sound Level (dB(A))	12Pa	High	33	37	40	43	43	43	45	47
		Medium	25	29	30	35	35	36	38	40
		Low	21	22	24	28	28	28	28	30
	30 Pa	High	38	40	43.5	45	45	45.5	47	49
		Medium	30	32	34.5	36	36	36.5	40	42
		Low	22	22	27	30	30	30	30	32
	50 Pa	High	41.5	43	45.5	47	47	48	49	51
		Medium	34	36	37	39	39	40	42	45
		Low	25	27	29	32	32	32	32	36
Fan	Type	Forward-curved multi-blade double inlet centrifugal fan								
Motor	Type	Brushless DC motor (embedded with AC-DC conversion)								
Heat Exchanger	Structure Type	Efficient double-flanged aluminum fins and copper tubes, expanded into								
	Maximum Operating Pressure (MPa)	1.6								
	Water Inlet/Outlet Pipe Diameter (inch)	Rc3/4 (Taper Pipe Female Threaded)								
	Water Flow (m ³ /h)	0.6	0.71	0.83	1.02	1.1	1.36	1.61	1.91	
Water Resistance	kPa	30	30	30	40	40	40	40	40	
Drain Pan	Condensate Water Pipe Diameter (inch)	Rc3/4 (Taper Pipe Male Threaded)								
Dimensions	Length (mm)	890		1050		1430		1730		
	Width (mm)	465		465		465		485		
	Height (mm)	242		242		242		262		
Net Weight (kg)		15		17		24		32		

★ Note:

- Cooling: supply water and return water temperatures 7/12°C; the dry/wet bulb temperature of air inlet is 27/19.5°C;
- Heating: supply water is 60°C or 45°C, water quantity being the same as during cooling; air return conditions: the dry bulb temperature of air inlet is 21°C;
- In the table, low static pressure indicates the air outlet static pressure at 0Pa (with air outlet and filter) and at 12Pa without air outlet and filter)
- The air flow in the table is obtained when the unit is running in dry state and the dry bulb temperature of air inlet is 20°C;
- Left & right swing manner cannot be adjusted on site.

Dimension

Low Noise DC Brushless FCU (Two Pipes & Four Pipes)

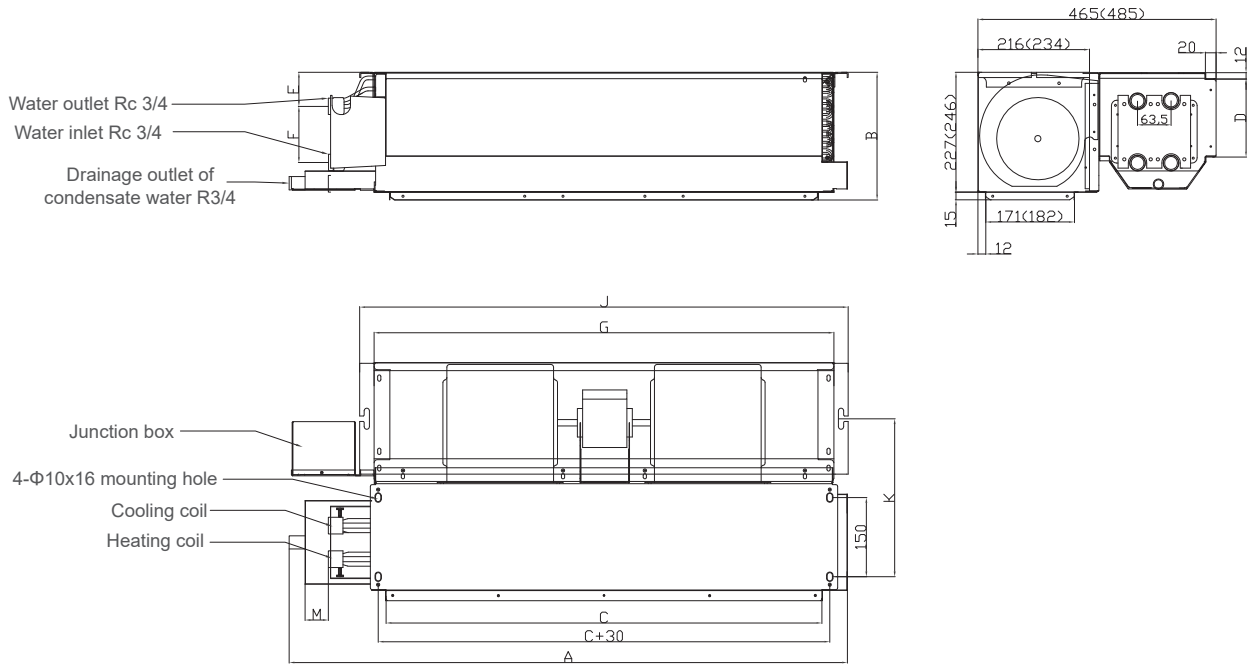

TCRQ	A	B	C	D	E	F	G	J	K	M
300C	890	242	665	150	54	118	712	739	300	45
400C	890	242	665	150	54	118	712	739	300	45
500C	1050	242	825	150	54	118	867	894	300	45
600C	1050	242	825	150	54	118	867	894	300	45
700C	1430	242	1205	150	54	118	1257	1284	300	45
800C	1430	242	1205	150	54	118	1257	1284	300	45
1000C	1730	261	1505	150	54	118	1552	1579	312	45
1200C	1730	261	1505	150	54	118	1552	1579	312	45

Note:

1. The unit with return air plenum does not have a return air flange, with other dimensions remaining the same
2. When vibration-absorbing lifting hooks are used for lifting the unit, tell the factory about it.

High Static Pressure Duct - TFM

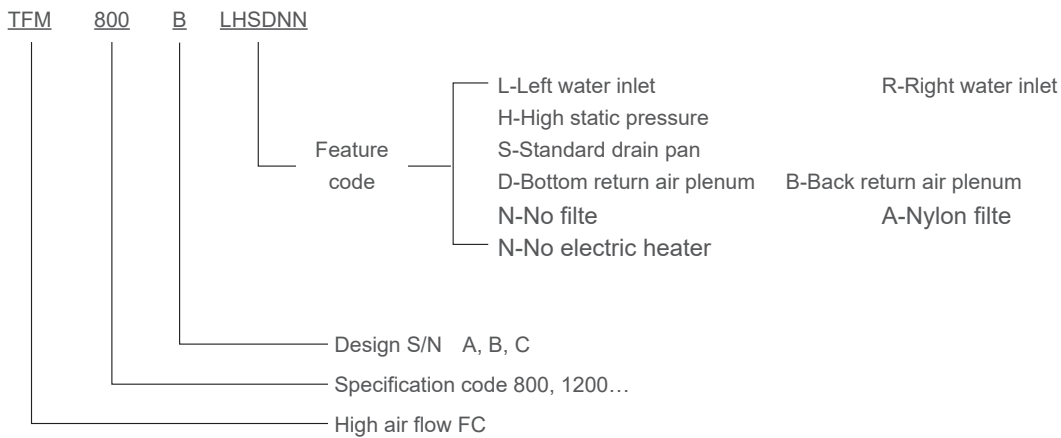

High Static Pressure Duct

Model TFM		800B	1000B	1200B	1600B	1800B	2000B	3000B
Rated Air Flow (m ³ /h)	High	1265	1510	1925	2490	2945	3880	5500
	Medium	1015	1215	1540	1990	2360	3100	4395
	Low	815	970	1230	1595	1890	2485	3520
Air Outlet Static Pressure (Pa)	High	130	130	130	130	130	130	130
Cooling Capacity (kW)	High	8.29	9.87	12.04	15.93	19.11	24.26	34.41
	Medium	6.64	7.90	9.63	12.75	15.29	19.39	27.51
	Low	5.30	6.31	7.70	10.20	12.22	15.53	22.01
Sensible Cooling Capacity (kW)	High	6.11	7.39	8.75	11.87	14.28	17.62	25.00
	Medium	4.89	5.91	6.99	9.51	11.42	14.09	19.98
	Low	3.92	4.73	5.60	7.61	9.14	11.29	15.99
Heating Capacity (kW)	High	12.37	15.19	19.60	24.56	28.66	39.47	55.99
	Medium	9.89	12.51	15.68	19.65	22.93	31.58	44.79
	Low	7.91	9.72	12.54	15.73	18.34	25.29	35.84
Power Input (W)	High	280	370	600	700	750	1200	1800
Sound Pressure Level (dB(A))	High	62	63	64	63	64.5	65	66
Fan	Type	Forward-curved multi-blade centrifugal fan (galvanized steel sheet)						
	Qty	1	1	1	2	2	2	3
Motor	Type	Single-phase capacitor motor						
	Insulation Class	B						
	Power Supply	220V~50Hz						
	Qty	1	1	1	1	2	2	3
Heat Exchanger	Structure Type	Aluminum-finned and copper-tube, mechanical expansion						
	Maximum Operating Pressure (MPa)	1.6MPa						
	Water Inlet/Outlet Pipe Diameter (inch)	R1 (taper pipe male threaded)					R1 ^{1/2} (taper pipe male threaded)	
	Water Flow (m ³ /h)	1.60	1.88	2.39	3.08	3.65	4.50	6.16
Water Pressure Drop (kPa)		6	14	25	20	25	35	45
Drain pan	Condensate Water Pipe Diameter	R1 (taper pipe male threaded)						
Dimensions	Length (mm)	860	860	960	1110	1260	1560	2010
	Width (mm)	820	820	820	820	820	820	820
	Height (mm)	430	430	430	430	430	430	430
Net Weight (kg)		50	50	56	65	76	94	126

Note:

1. Cooling capacity test conditions: supply water and return water temperatures 7/12°C; air return conditions: the dry/wet bulb temperature of air inlet is 27°C;
2. Heating capacity test conditions: supply water is 60°C, water quantity being the same as during cooling capacity test; air return conditions: the dry bulb temperature of air inlet is 21°C;
3. The air flow in the table is obtained when the unit is running in dry state and the dry bulb temperature is 20°C
4. When FCU residual pressure consumption is 80Pa, moisture might occur;
5. Unless specified otherwise, the unit comes with the following return air plenum
6. The sound pressure level in the table is obtained in a semi-anechoic chamber with noise at 11.5dB(A);

Dimension

High Pressure Duct FCU

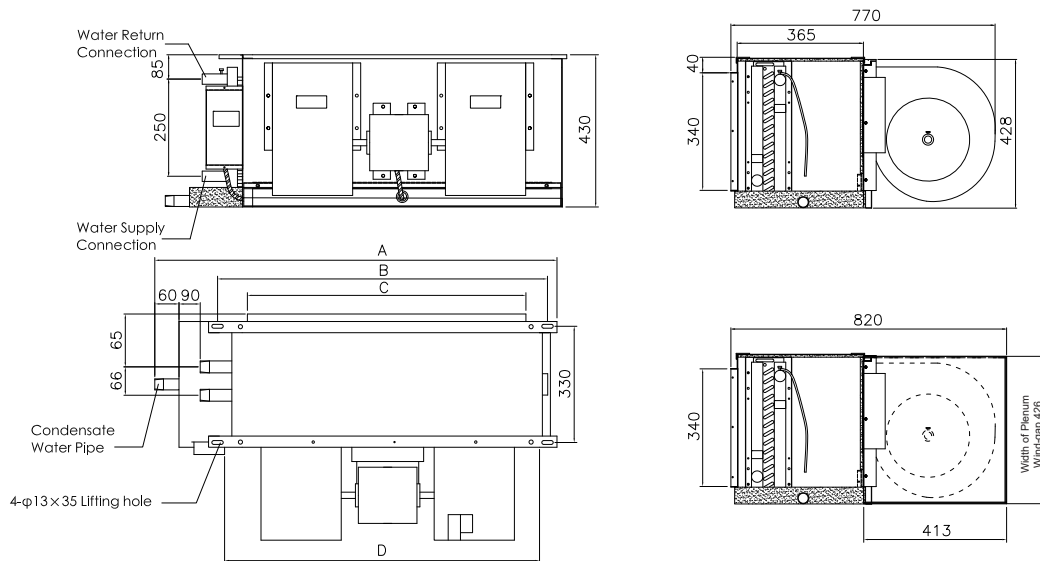

Model TFM	A	B	C	D	Inlet/outlet Pipe	Condensate Water Pipe	Motor Quantity (S/H)	Fan Quantity
800B	860	683	530	653	R1	R1	1/1	1
1000B	860	683	530	653	R1	R1	1/1	1
1200B	960	783	630	653	R1	R1	1/1	1
1600B	1110	953	800	753	R1	R1	1/1	2
1800B	1260	1083	930	923	R1	R1	1/2	2
2000B	1560	1403	1250	1373	R1 ^{1/2}	R1	2/2	2
3000B	2010	1853	1700	1823	R1 ^{1/2}	R1	3/3	3

Round Flow Cassette - TKM



Characteristics:

- 360° air outlet, no blind spot.
- Low noise
The quality heat insulating and anechoic material is used to minimize the unit vibration and noise. The 3D aerofoil-type blade fan with a large diameter is used to ensure low speed and low noise.
- Compact design, built-in drain pump

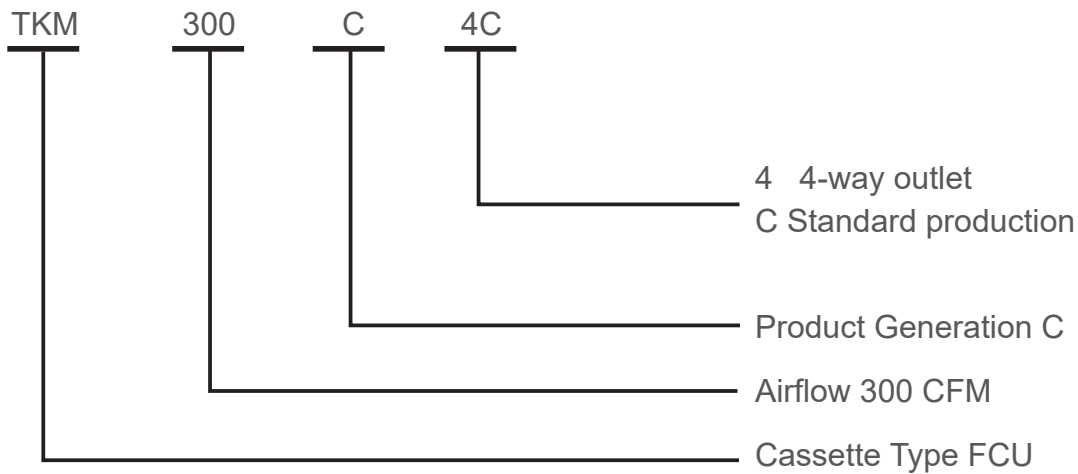
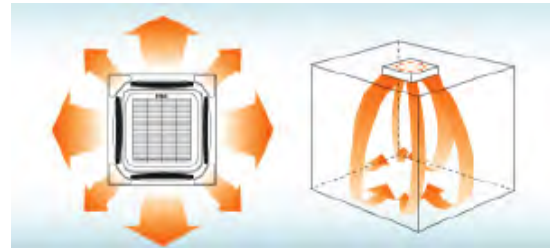

Round Flow Cassette

Model TKM		300C4C	400C4C	500C4C	600C8C	800C8C	1000C8C	1200C8C
Rated Air Flow (m ³ /h)	High	510	680	850	1020	1360	1700	2040
	Medium	420	560	650	870	1150	1450	1750
	Low	350	460	520	715	950	1190	1430
Cooling Capacity (W)	High	2700	3600	4500	6000	8000	9500	10800
	Medium	2410	3100	3830	5150	6655	8285	9430
	Low	2140	2750	3360	4530	5860	6950	8200
Heating Capacity (W)	High	4050	5400	6750	10000	12500	15500	17000
Power Input (W)	High	50	60	74	85	108	144	183
FCEER	High	49	54	54	60	62	56	51
FCCOP (Water Inlet: 60°C)	High	73	80	82	101	97	92	81
Sound Level (dB(A))	High	39	41	43	40	41	45	48
Fan	Type	Centrifugal fan						
Motor	Type	Single-phase capacitor motor						
Heat Exchanger	Structure Type	Efficient double-flanged aluminum fins and copper tubes, expanded into						
	Maximum Operating Pressure (MPa)	1.6						
	Water Inlet/Outlet Pipe Diameter (inch)	Rc3/4 (Taper Pipe Female Threaded)						
	Water Flow (m ³ /h)	0.48	0.64	0.79	1.1	1.42	1.7	1.85
Water Resistance	kPa	30	30	30	35	40	40	40
Drain Pan	Condensate Water Pipe Diameter	Φ20						
Dimensions (Excluding Decorative Panel)	Length (mm)	570	730	840	840	840	840	840
	Width (mm)	570	730	840	840	840	840	840
	Height (mm)	250	290	230	310	310	310	310
Decorative Panel Dimensions	Length (mm)	650	850	950	950	950	950	950
	Width (mm)	650	850	950	950	950	950	950
Net Weight	kg	23	33	29	34	34	34	35

★ Note:

1. Cooling: supply water and return water temperatures 7/12°C; the dry/wet bulb temperature of air inlet is 27/19.5°C;
2. Heating: supply water is 60°C, water quantity being the same as during cooling; air return conditions: the dry bulb temperature of air inlet is 21°C;
3. The air flow in the table is obtained when the unit is running in dry state and the dry bulb temperature of air inlet is 20°C;
4. The sound pressure level in the table is obtained in a semi-anechoic chamber with noise at 11.5dB(A);
5. TKM***C series come with automatic guide plate drive mechanism and pump;

Dimension

Cassette Type FCU

TKM300-500(Dimensions in brackets for TKM500)

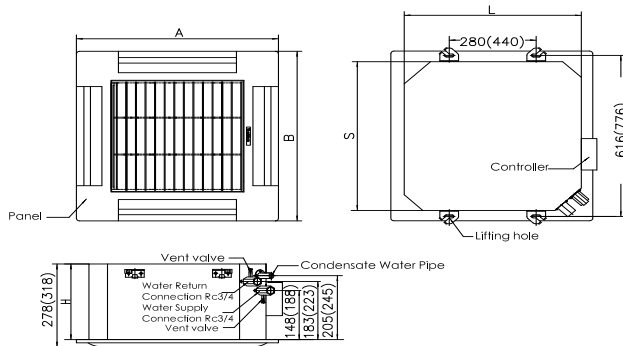

TKM600-1200(Dimensions in brackets for TKM600)

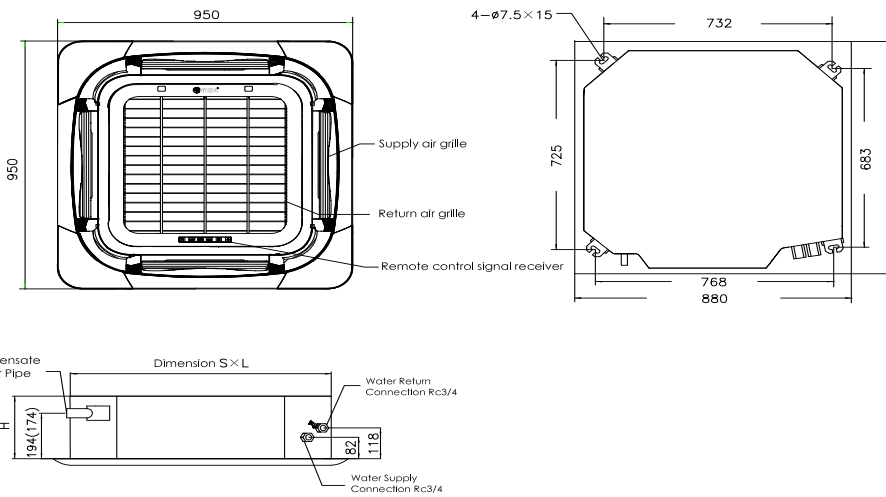

TKM	TKM300	TKM400	TKM500	TKM600	TKM800	TKM 1000	TKM 1200
Panel Dimesion (A x B)	650x650	650x650	850x850	950x950	950x950	950x950	950x950
Unit Dimesion (S x L x H)	570x570x250	570x570x250	730x730x290	840x840x230	840x840x310	840x840x310	840x840x310
Weight (kg)	23	23	33	29	34	34	35

Ceiling & Floor - TC



Characteristics:

- Flexible installation, ceiling or floor mounte
- Automatic horizontal and vertical air flo
- One side access hole ,easy for maintenance

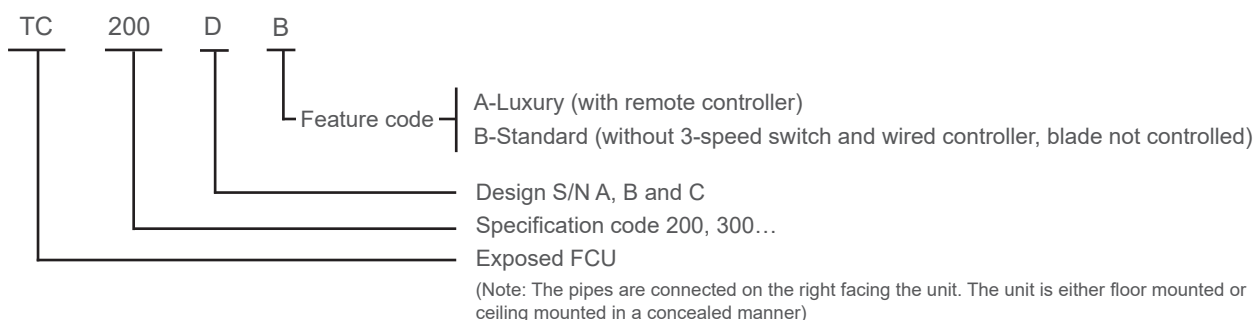

Model TC		200D	300D	400D	500D	600D	800D	1000D	1200D	1400D
Rated Air Flow (m3/h)	High	350	520	680	850	1030	1360	1700	2040	2380
	Medium	280	440	560	700	870	1255	1450	1830	2100
	Low	230	350	410	570	740	1080	1160	1500	1650
Cooling Capacity (W)	High	1970	2850	3600	4300	5400	6600	8400	9600	10500
	Medium	1675	2400	3060	3655	4590	5610	7140	8160	8900
	Low	1380	1995	2520	3010	3780	4620	5880	6720	7350
Heating Capacity (W)	High	3200	4500	5600	6800	8600	10500	13500	15000	16800
	Medium	2680	3825	4760	5780	7310	8900	11500	12750	14280
	Low	2200	3150	3920	4760	6020	7350	9450	10500	11760
Power Input (W)	High	37	52	62	76	106	134	165	189	228
FCEER	High	51	52	54	52	49	46	48	47	42
FCCOP (Water Inlet: 60°C)	High	83	83	84	82	78	74	77	74	68
Sound Level (dB(A))	High	37	39	41	43	45	46	48	50	52
Fan	Type	Forward-curved multi-blade double inlet centrifugal fan								
Motor	Type	Single-phase capacitor motor								
Heat Exchanger	Structure Type	Efficient double-flanged aluminum fins and copper tubes, expanded into								
	Maximum Operating Pressure (MPa)	1.6								
	Water Inlet/Outlet Pipe Diameter (inch)	Rc3/4 (Taper Pipe Female Threaded)								
	Water Flow (m3/h)	0.34	0.49	0.62	0.74	0.89	1.12	1.44	1.65	1.81
Water Resistance	kPa	12	14	22	26	20	20	24	29	
Drain Pan	Condensate Water Pipe Diameter	Φ25								
Dimensions	Length (mm)	905			1288			1672		
	Width (mm)	243			243			243		
	Height (mm)	673			673			673		
Net Weight	kg	25			40			45		

★ Note:

1. Cooling: supply water and return water temperatures 7/12°C; the dry/wet bulb temperature of air inlet is 27/19.5°C;
2. Heating: supply water is 60°C, water quantity being the same as during cooling; air return conditions: the dry bulb temperature of air inlet is 21°C;
3. The air flow in the table is obtained when the unit is running in dry state and the dry bulb temperature of air inlet is 20°C;
4. The sound pressure level in the table is obtained in a semi-anechoic chamber with noise at 11.5dB(A);
5. TC**DB series do not contain a wired controller; TC**DA series contain a remote controller;
6. Thermostat is optional with three speed levels and can be connected to electric valve to realize temperature regulation;
7. The pipes are connected on the right facing the unit;
8. The unit can be in vertical or ceiling installation;

Dimension

Floor Ceiling Type FCU

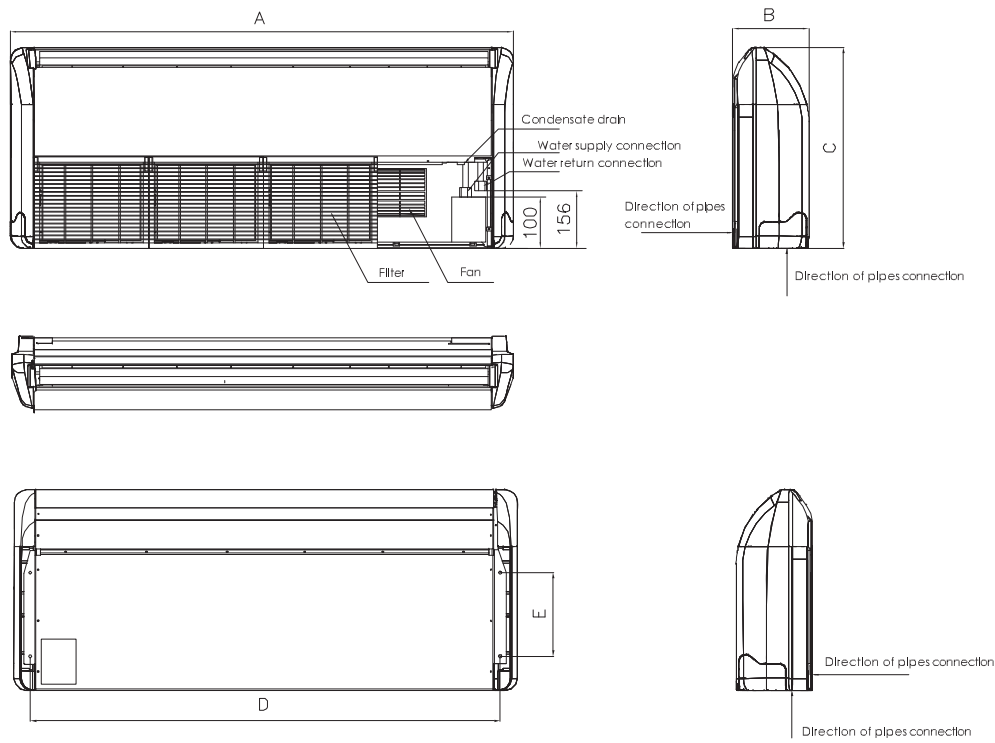

TC	200	300	400	500	600	800	1000	1200	1400
Dimension	905x243x673				1288x243x637		1672x243x673		
Steeve Pitch	801x280				1184x280		1569x280		
Fan Quantity	2	2	2	2	3	3	4	4	4

Note

A series of 14 horizontal grey bars, each with a thin black border, stacked vertically to provide a space for writing notes.



Follow the Official Site of
«TICA SNG» LLC

TICA SNG LLC

Tel.: +7 495 127 79 00,
+7 915 650 85 85,
+7 969 190 85 85

E-mail: info@tica.pro

www.tica.pro

Note: Due to constant improvement and innovation of TICA's products, the product models, specifications and parameters contained in this document are subject to change without prior notice